

## SOLENOID Valve -- Type SC

Port Size 9 - 66mm (3/8" - 2-5/8")

For , R12, R22, R502 and other common refrigerants

### FEATURES

- Pilot Operated
- Interchangeable Capacity Cartridges Same as Used on (S)PORT EPR's
- Low Pressure Drop
- Manual Opening Stem
- All Service from the Top
- Sweat-in-place Without Disassembly
- Maximum Opening Pressure Difference (MOPD): 20.7 bar (300 psig)
- Design Pressure (MRP): 31.0 bar (450 psig)
- Molded Class "F" Coil Construction
- Pilot Light Available

### DESCRIPTION

The new SC suction solenoid for commercial applications was developed by the Refrigerating Specialties Division of Parker Hannifin as an alternative low pressure drop shut off valve in a wide range of both port and connection sizes. With cartridge (port) sizes available as large as 2-5/8", SC solenoids are capable of handling greater flow rates than other commercially available valves for suction applications in a non-flanged design. In addition, this unique design incorporates the same concept of cartridge interchangeability as found in Parker's popular (S)PORT evaporator pressure regulators.

This innovative design actually utilizes the same capacity cartridges (and valve bodies) as those used with the (S)PORT regulator series, as well as the same solenoid actuator, solenoid coil, and splice box coil housing. Capacity cartridges can be changed by simply unscrewing the valves' four bonnet bolts in order to remove the adapter and cartridge assemblies. With this flexible line of solenoid valves now supplementing the existing line of



(S)PORT regulators having these same characteristics, a single reliable source for all suction line components is now available. This ductile iron-bodied solenoid valve with brazed copper couplings is suitable for most common refrigerants, certain oils and other fluids approved for use in refrigeration. This valve may be opened by means of a manual opening stem for servicing or in case of electrical power failure. These solenoids are an integrated assembly of (3) three modules: 1) A body containing no moving parts; 2) A capacity cartridge, which contains both piston and modulating plug, and 3) an adapter on which the pilot solenoid is mounted and which incorporates a manual opening stem which bypasses the pilot pressure around the solenoid and directs it to the top of the valve piston.

### ORDERING GUIDE

Parker's SC solenoid series can be ordered using the same numbering system which is used with (S)PORT pressure regulators. The first two digits following the "SC" valve type designate the valve's port size in eighths of an inch, while the second two digits designate the connection size, also in eighths of an inch. For example, an SC-07-09 would call for a 7/8" Port (or cartridge) size and a 1-1/8" ODS connection. Both (S)PORT regulators and SC solenoids are frequently ordered less coil and coil housing for inventory purposes. Should a solenoid coil be desired however, please indicate the voltage requirement when ordering.

### PRINCIPLES OF OPERATION

The R/S Type SC is a pilot operated solenoid. The valve in its closed position, with the solenoid coil de-energized and the plunger and piston plug in the seated position, is shown in Figure 1. Electrical energizing of the solenoid coil forms a magnetic field, pulling up the plunger, lifting it off its seat. Upward motion of the plunger permits entrance of the fluid from the valve inlet

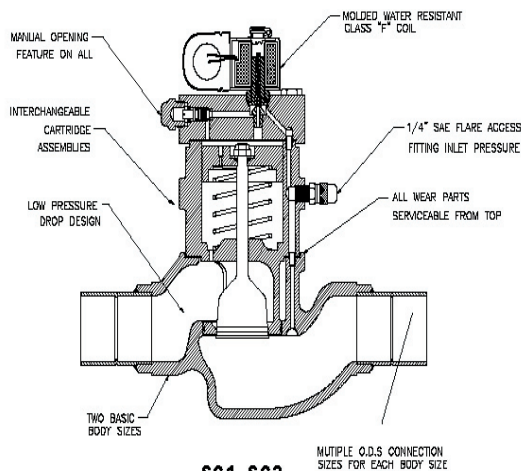

Figure 1

through the adapter and down through the pilot port to the top of the piston. This forces the piston downward and pushes the main port plug open, thereby permitting flow of the refrigerant through the valve. The closing spring meanwhile is held in a compressed position. De-energizing of the solenoid coil permits the spring-assisted plunger to reseat, stopping the flow through the pilot port. Bleed-off, through the bleed hole in the piston, decreases the pressure above the piston and allows the closing spring to force the main port plug upward into a closed position to stop the flow. The pressure difference across the valve, acting upon the area of the valve seat, plus the force of the closing spring, holds the main port plug in a tightly closed position.

## MANUAL OPENING STEM

The manual opening stem on the SC solenoid is for the purpose of opening the valve without energizing the solenoid coil. Refer to the exploded view and the parts list for location of the stem and other related parts. For access to the stem, the seal cap must be removed. This must be done with caution as refrigerant may be trapped inside the seal cap. Manual opening is accomplished by turning the stem counter clockwise until stopped. To reset for automatic operation turn stem clockwise until seated.

## INSTALLATION

The solenoid valve can be mounted in a horizontal or vertical line with the flow in the direction of the arrow on the valve body. Protect the inside of the solenoid valve from moisture, dirt and chips during installation. These valves may be soldered into the line without disassembly. A wet cloth should be wrapped around the valve and the soldering flame should be directed away from the valve body. The SC solenoid valve must be installed with the arrow on the valve body in the direction of flow through the valve. If the valve is backwards, the flow will not be stopped when the valve is electrically de-energized. Like all Solenoid Valves, the SC can stop flow only in the direction from normal inlet to normal outlet (as shown by the arrow on the body). If reversal of pressure occurs in the system so the outlet pressure exceeds the inlet pressure, the plug will be blown away from its seat and reverse flow will occur. If a system has this type of pressure reversal, a check valve such as Refrigerating Specialties Division Type CK4A in series with the solenoid valve will prevent flow reversal. (The CK4A must be installed downstream of the solenoid to avoid trapping liquid when the solenoid is de-energized.)

## ELECTRICAL

The Refrigerating Specialties Division molded water resistant Class "F" solenoid coil, which is standard

on the SC solenoid, is designed for long life and powerful opening force. The standard coil housing meets NEMA 3R and 4 requirements. This sealed construction can withstand direct contact with moisture and ice. The Class "F" solenoid coil and splice box housing should be used on low side applications only. Due to the lower temperature rating of the Class "F" coil, it should not be used with solenoid valves applied to high side duty. For those applications, the Class "H" coil and the general purpose housing should be used which are standard on Parker Refrigerating Specialties Division S81 and S82 solenoid valves.

A solenoid coil should never be energized except when mounted on its corresponding solenoid tube. The molded Class "F" coil is available from stock with most standard voltages. However, coils are available for other voltages and frequencies.

The solenoid coil must be connected to electrical line with volts and Hertz same as stamped on coil. The supply circuits must be properly sized to give adequate voltage at the coil leads even when other electrical equipment is operating. The coil is designed to operate with line voltage from 85% to 110% of rated coil voltage. Operating with a coil voltage above or below these limits may result in coil burnout. Also, operating with a coil voltage below the limit will definitely result in lowering the valve's maximum opening pressure differential. Power consumption during normal operation will be 10.2 watts or less.

The coil housing washer (item #40) should be installed on the solenoid operator (#36), before the coil housing (#39) and the coil cover clip (#41) are installed.

This "Stack-up" maintains the coil firmly in place and prevents excessive vibration of the entire coil housing assembly when the coil is energized.

## SERVICE POINTERS

1. Failure to Open: (a) Coil is of incorrectly high voltage. See "Electrical". Check voltage printed on the coil. (b) Line voltage is abnormally low. See "Electrical". Check line voltage at coil leads with a voltmeter. (c) Failure to electrically energize. Check control circuit. (d) Pressure difference across valve is too high. The SC will open against a maximum pressure difference across the valve of 21 bar (300 psig). (e) Solenoid Coil is burned out. See "Electrical", and replace with proper coil. (f) Plunger Assembly is sticking. To disassemble the SC for inspection of internal parts (after pumping out the system as required): disconnect power source to Solenoid Coil, remove (#36) Solenoid Operator Assembly, then Adapter. Remove every trace of dirt from Adapter and Cartridge Assembly. Thoroughly clean all parts and reassemble using a light film of refrigerant oil.
2. Failure to Close: (a) Electrical control circuit is not opening properly. Check wiring and controls. (b) There are chips or dirt on the Pilot Seat or the Piston Plug Seat, preventing proper seating.

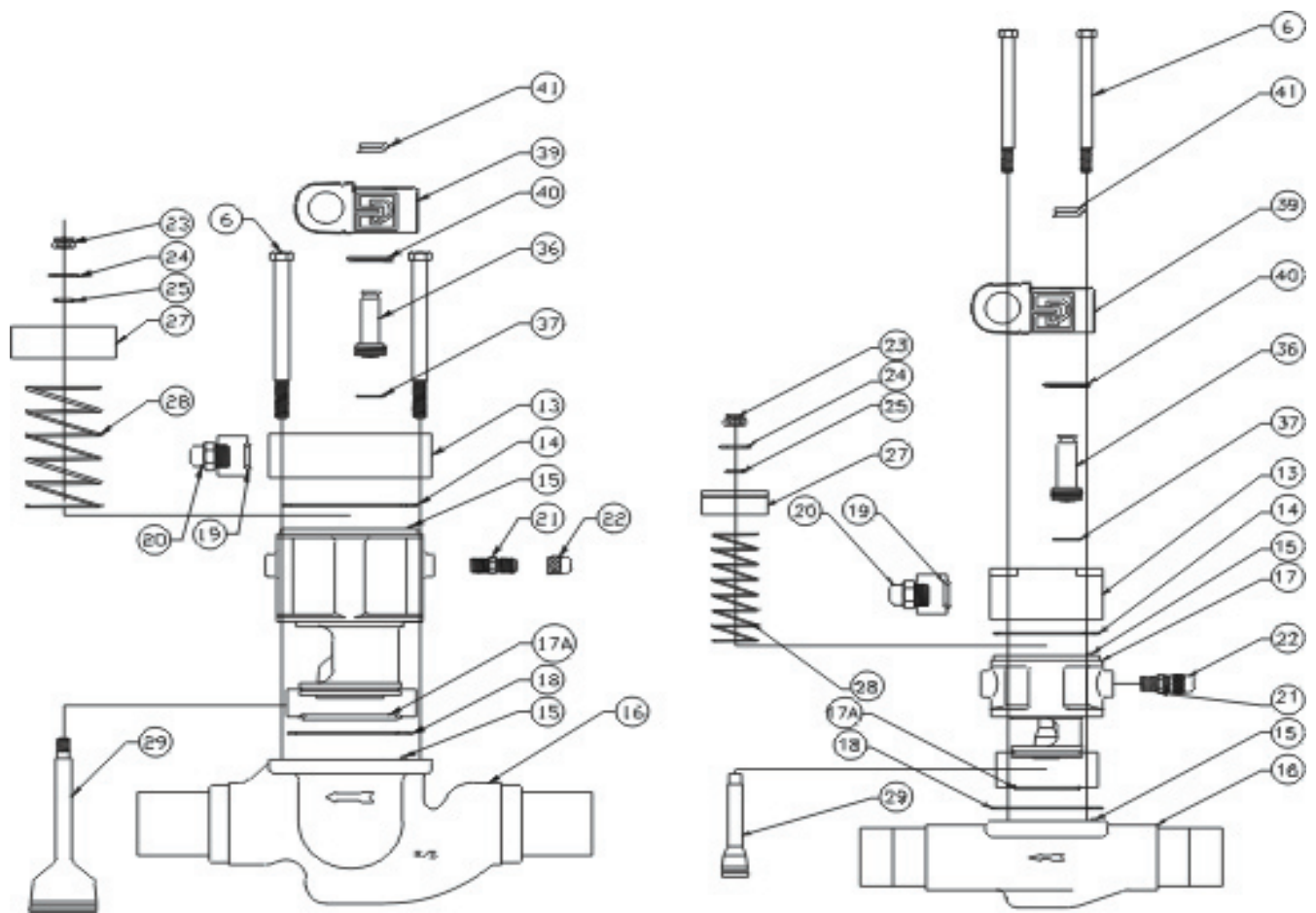

Repair Kits for SC1 and SC2 Solenoid Valves				
Item No.	Description	Qty.	SC1 3 thru 11	SC2 13 thru 21
6	Bolt Package	4	204677	204676
13,14,19,20,36,37	Adapter Assembly	1	204671	204670
15	Pin, Locating	1	N/A Separately	
16	Body Assembly	1	N/A Separately	
14,17,17A,18	Cartridge Kit (3/8") - 03	1	204452	-----
14,17,17A,18	Cartridge Kit (5/8") - 05	1	204453	-----
14,17,17A,18	Cartridge Kit (7/8") - 07	1	204454	-----
14,17,17A,18	Cartridge Kit (1 1/8") - 09	1	204455	-----
14,17,17A,18	Cartridge Kit (1 3/8") - 11	1	204456	-----
14,17,17A,18,26,30	Cartridge Kit (1 5/8") - 13	1	-----	207159
14,17,17A,18,26,30	Cartridge Kit (2 1/8") - 17	1	-----	207160
14,17,17A,18,26,30	Cartridge Kit (2 5/8") - 21	1	-----	207161
30	Items: 27,28,29	1	Only with cartridge kit	
39,40,41	Coil and Housing Kit 120/60, 110/50	1	206004	

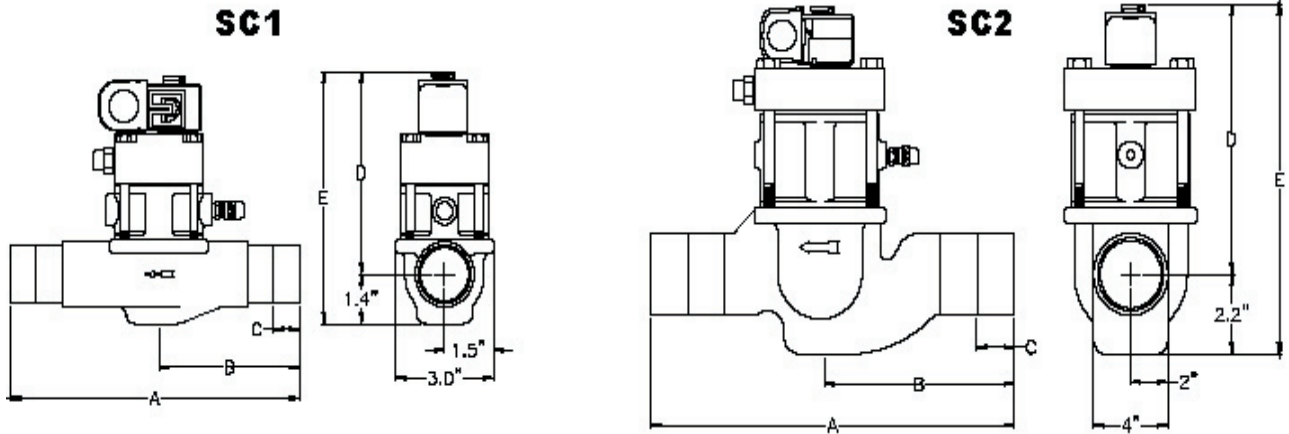

Type		SC1					SC2		
Connection Size		22 mm	28 mm	35 mm	42 mm	54 mm	42 mm	54 mm	67 mm
A	Inch	9.6	9.6	9.4	9.9	11.1	11	12	13.5
	mm	244	244	239	251	282	279	305	343
B	Inch	4.8	4.8	4.7	5	5.6	5.9	6.4	7.1
	mm	122	122	119	127	142	149	162	181
C	Inch	0.8	0.9	1	1.1	1.2	1.1	1.4	1.7
	mm	20	23	25	28	30	28	36	44
D	Inch	5.5	5.5	5.5	5.5	5.5	7.2	7.2	7.2
	mm	140	140	140	140	140	183	183	183
E	Inch	6.9	6.9	6.9	6.9	6.9	9.4	9.4	9.4
	mm	175	175	175	175	175	239	239	239

Bolt Diameter	Valve Size	Torque
1/4" (6mm)	03-21	8ft lb (1.1 mkg)
5/16" (mm)	13-21	12 ft lb (1.7 mkg)
Jam Nut	13-21	8 ft lb (1.1 mkg)
Solenoid Operator	All	6 ft lb (0.0mkg)

Disassemble and clean Valve as outlined in 1(f) above. (c) Piston Plug Seat or Pilot Seat may be worn or damaged and therefore leaking. Disassemble and clean Valve as outlined in 1(f) above. If any of these parts need replacing, it is advisable to replace using the proper replacement kit. (d) Manual Opening Stem is turned all or party out and permitting flow through the valve.

3. Leakage through Valve: See (2) above.

**WARRANTY**

All Refrigerating Specialties Products are warranted against defects in workmanship and materials for a period of one year from date of shipment from the factory. This warranty is in force only when products are properly installed, maintained and operated in use and service as specifically stated in Refrigerating Specialties Catalogs or Bulletins for normal refrigeration applications, unless otherwise approved in writing by Refrigerating Specialties Division. Defective products or parts thereof, returned to the factory with transportation charges prepaid and found to be defective by factory inspection will be replaced or repaired at Refrigerating Specialties, option, free of charge, F.O.B. factory. Warranty does not cover products which have been altered or repaired in

the field; damaged in transit, or have suffered accidents, misuse, or abuse. Products disabled by dirt, or other foreign substances will not be considered defective. THE EXPRESS WARRANTY SET FORTH ABOVE CONSTITUTES THE ONLY WARRANTY APPLICABLE TO REFRIGERATING SPECIALTIES PRODUCTS, AND IS IN LIEU OF ALL OTHER WARRANTIES, EXPRESS OR IMPLIED, WRITTEN OR ORAL. INCLUDING ANY WARRANTY OF MERCHANTABILITY, OR FITNESS FOR A PARTICULAR PURPOSE. No employee, agent, dealer or other person is authorized to give any warranties on behalf of Refrigerating Specialties, or to assume, for Refrigerating Specialties, any other liability in connection with any of its products.

**SAFE OPERATION (See Bulletin RSB)**

People doing any work on a refrigeration system must be qualified and completely familiar with the system and the valves involved, or all other precautions will be meaningless. This includes reading and understanding pertinent product bulletins and the current Bulletin RSB prior to installation or servicing work.

