

A SPORLAN REFRIGERANT DISTRIBUTOR FOR MOST REQUIREMENTS

Thoroughly engineered, continually improved and laboratory and field tested for over 50 years!

- Reliable Sporlan machining quality.
- Sizes and capacities for most applications.
- Easy to solder. Steel models feature trepanned circuits for simplified welding.
- Interchangeable nozzle permits custom selection.
- Can be installed in any position.
- Adapts to, and compliments, Sporlan quality expansion valves.
- Can be applied to any make multi-circuit evaporator coil.
- Allows visual inspection of solder joints.
- Permits use of a probe wire or air jet to test for plugged circuits at distributor or evaporator coil.

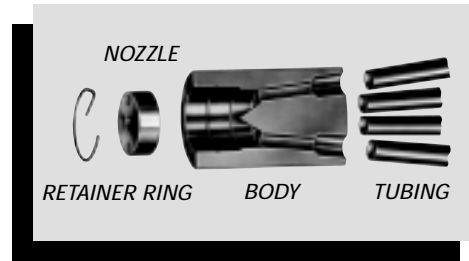

CONTENTS

Refrigerant Distributors	3
The Distribution Problem and Its Solution	3
General Engineering Data	4
Application Instructions	5
Brazing, Testing and Installation Procedures	5
Selection and Ordering Procedure	7
Quick Reference Guide	
■ Removable Nozzles	8
■ Permanent Nozzles	9
■ Obsolete Distributors	9
Capacity Tables	
■ Distributor Tube Capacities - Table A	10
■ Distributor Nozzle Capacities - Table B	11
■ Pressure Drop vs. Distributor Loading - Table C	13
Distributors - Specifications	
■ SAE Flare	14
■ ODF Solder	16
■ Flange	
■ Brass	18
■ Aluminum	19
■ SAE Flare with Auxilliary Side Connection	22
■ ODF Flare with Auxilliary Side Connection	23
Auxilliary Side Connectors (ASC) - Specifications	24
Distributors - Ammonia	
■ Aluminum & Steel	26
■ Steel with Auxilliary Side Connection	27

REFRIGERANT DISTRIBUTOR

What is it?

The refrigerant distributor is a device connected to the outlet of a thermostatic expansion valve (TEV). The outlet of the distributor is machined to accept tubing which connects the distributor to each evaporator coil circuit.

What is its function?

The refrigerant distributor equally distributes refrigerant flow from the thermostatic expansion valve (TEV) into each circuit of a multi-circuit evaporator coil.



PLATE EVAPORATOR

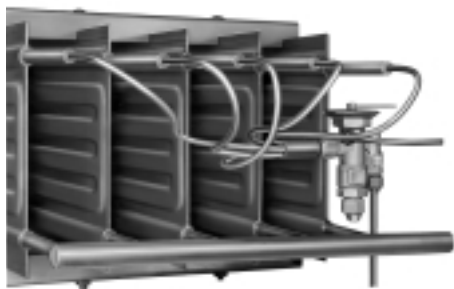

THE DISTRIBUTION PROBLEM

A portion of the liquid refrigerant passing through the thermostatic expansion valve (TEV) normally flashes, resulting in two-phase (liquid and vapor) flow at the valve outlet, see Figure 1. This mixture is predominately liquid by weight, but the vapor occupies most of the volume. For a typical R-22 application, the percentage, by weight and volume, of liquid and vapor flow entering the evaporator coil are listed below:

REFRIGERANT	% WEIGHT	% VOLUME
Liquid	77	7
Vapor	23	93

The above values are based on 110°F liquid refrigerant entering the TEV, and a 45°F evaporating temperature. In this example, liquid represents 77% of the flow by weight, though it only amounts to 7% of the flow volume.

An additional problem arises due to the fact that liquid and vapor move at different velocities. This is sometimes referred to as slip, since gravity has a greater influence on the liquid portion of the flow.

If a simple header is used to divide the flow into each of the evaporator circuits, the circuits will not receive equal

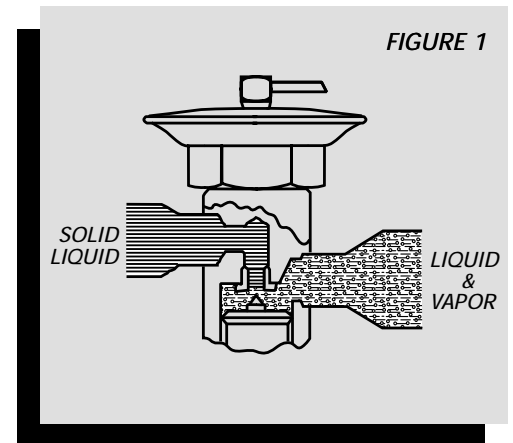

FIGURE 1

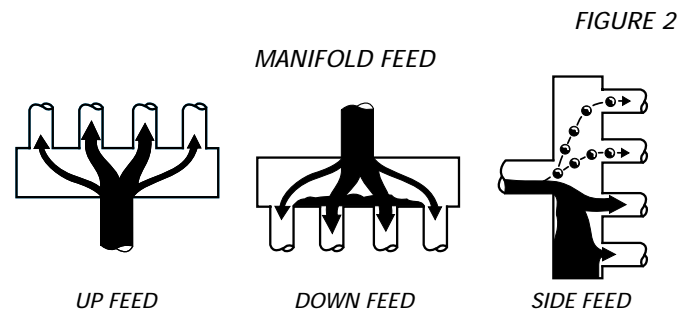

FIGURE 2

FLOW WILL BE GREATEST TO PATH OF LEAST RESISTANCE

amounts of refrigerant. The lower circuits of the evaporator invariably receive the most liquid, possibly causing TEV hunting and floodback problems. The upper circuits are then starved, reducing the effective evaporator surface, see Figure 2.

To achieve proper distribution, the liquid portion of the two-phase flow must be divided equally to each evaporator coil circuit. The solution: [1] mix the liquid and vapor portions of the refrigerant flow; and [2] maintain a homogeneous two-phase mixture until equal portions of the flow are divided into each evaporator circuit.

HOW A SPORLAN DISTRIBUTOR SOLVES THIS PROBLEM

The two-phase refrigerant flow leaving the TEV enters the distributor nozzle. The nozzle increases the velocity of the two-phase flow, mixing its liquid and vapor components. Furthermore, the nozzle is positioned such that flow is focused onto the dispersion cone, equally dividing the mixture into passageways spaced evenly around the cone. The refrigerant is then conveyed, by the distributor tube, to each evaporator circuit.

Pressure drop across the Sporlan distributor creates the high velocity necessary to distribute the refrigerant flow effectively. High velocity is the key to the distributor's success. Pressure drop across the nozzle focuses the flow, and provides the necessary mixing. Pressure drop across the distributor tubes assists in balancing the flow as it enters the distributor passageways. As a result, distributor tube and nozzle sizing is critical to proper distributor operation.

OPERATION OF SPORLAN PRESSURE DROP TYPE DISTRIBUTORS

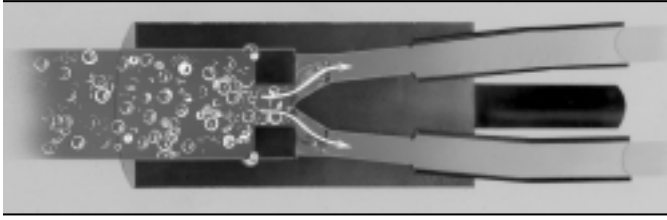

- 1 - Velocity of refrigerant LIQUID-VAPOR MIXTURE increased by flow through nozzle orifice
- 2 - Orifice provides homogeneous MIXING through turbulence created by pressure drop
- 3 - Refrigerant MIXTURE divided by conical button while still at high velocity
- 4 - MIXTURE fed equally to circuits

Distributor pressure drop does not reduce system capacity. Furthermore, pressure drop across a Sporlan distributor assures the thermostatic expansion valve diaphragm case remains warmer than its sensing bulb.

On systems using valves with (MOP) type gas-cross charges, the charge can migrate from the bulb to the diaphragm case. This occurs if the valve body becomes colder than the suction line.

Using a Sporlan distributor prevents charge migration. Because of the pressure drop, the pressure and temperature at the valve outlet are held considerably higher than the suction gas temperature at the sensing bulb.

GENERAL ENGINEERING DATA

The function of the refrigerant distributor is to equally distribute refrigerant flow from the thermostatic expansion valve (TEV) into each circuit of a multi-circuit evaporator coil. This function is vital to proper system performance since refrigerant distribution directly affects the operation of the thermostatic expansion valve and the evaporator coil. If the refrigerant is poorly distributed through the evaporator coil, the thermostatic expansion valve will often hunt and may result in occasional floodback to the compressor. Evaporator performance will also decrease since the circuits in the coil will not remain fully active.

Refrigerant distributors for the following refrigerants may be selected from the ratings provided in Tables A, B, and C: R-12, R-22, R-134a, R-401A, R-401B, R-402A, R-402B, R-404A, R-407A, R-407C, R-408A, R-409A, R-410A, R-502, and R-507. Distributor tube ratings are based on a 30 inch tube length, 100°F refrigerant liquid temperature entering the TEV, and a 10 psi pressure drop across the tubes and the internal passageways of the distributor. Nozzle ratings are based on a 100°F refrigerant liquid temperature entering the TEV, and the pressure drop values listed in Table B. For distributor tube lengths other than 30 inches, apply the appropriate correction factor, shown in Table A, to the distributor tube ratings. Similarly, apply the appropriate correction factor, shown in Table A, for refrigerant liquid temperatures other than 100°F. The liquid temperature correction factor applies to both distributor tube

and nozzle ratings. The distributor tube length correction factor only applies to the distributor ratings.

Refrigerant distributors for R-717 (ammonia) applications can be selected from the ratings provided in Tables A, B, and C. Distributor tube ratings for ammonia are based on a 30 inch tube length, 86°F refrigerant liquid temperature, and a 10 psi pressure drop across the distributor tubes and internal passageways. Nozzle ratings are based on an 86°F refrigerant liquid temperature and a 30 psi pressure drop across the nozzle. Correction factors for other tube lengths and liquid refrigerant temperatures are shown in Table A.

The table below lists distributor tube and nozzle pressure drops at rated capacities (100% loading).

REFRIGERANT	TUBE AP (psi)	NOZZLE AP (psi)	TOTAL AP* (psi)
R-12, R-134a, R-401A, R-401B, R-409A	10	15	25
R-22, R-402A, R-402B, R-404A, R-407A, R-407C, R-408A, R-502, R-507	10	25	35
R-410A	10	35	45
R-717 (ammonia)	10	30	40

**For systems that regularly operate between 50% and 100% of full load capacity, it is common to select a nozzle and tubes that have a combined pressure drop of 10 psi greater than this table. This is a good practice. The only precaution is to verify the thermostatic expansion valve capacity at the reduced pressure drop across its port.*

The percentage of distributor tube and nozzle loadings are determined by dividing the actual capacity by the rated capacity provided in the tables. This value allows estimating of the pressure drop across the distributor from Table C. For both the distributor tubes and nozzle, the percentage of loading should fall between 50% and 200% for all system operating conditions. Loading less than 50% can result in poor distribution. The nozzle loading is generally more critical to optimum distributor performance. Loading greater than 200% results in a high pressure drop across the distributor, making proper TEV sizing difficult.

An example of a distributor selection is provided on pages 7 and 8. When determining pressure drop across a TEV, it is necessary to first determine the pressure drop across the distributor and tube assembly. This value is then subtracted from the available pressure drop across the TEV.

VARIABLE SYSTEM CAPACITY

Certain refrigeration systems operate over wide ranges of evaporator temperatures. For these systems, the distributor tube and nozzle selection should be checked over the entire range of system operation. For systems using compressors with capacity reduction, the distributor tube and nozzle sizing should be checked for both the minimum and maximum load conditions. The nozzle should be at least 50% loaded at the minimum load condition.

If the distributor nozzle cannot be maintained with 50% to 200% loading due to load variation, consider using two or more TEVs to control the load. Refer to Bulletin 10-9 for further information.

APPLICATION INSTRUCTIONS

For each circuit to offer equal resistance distributor tube lengths must be the same. Furthermore, the distributor tubes should be bent carefully. Sharp bends and kinks reduce the cross sectional area of the tube, increasing resistance to refrigerant flow.

Since the distributor is designed to disperse equal amounts of refrigerant to each circuit, it is essential the heat load on all circuits of the evaporator coil be the same. Otherwise, the effect is the same as poor distribution. The circuits with the greatest loading are starved, while the circuits with the least loading are overfed, see Figure 3. This condition often causes the expansion valve to hunt, resulting in occasional floodback to the compressor.

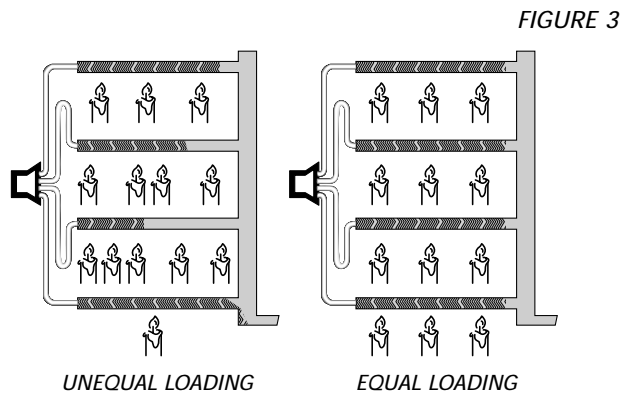

Optimum distributor performance is obtained when the distributor is mounted directly to the TEV outlet. If the distributor cannot be mounted directly to the valve outlet, it can be connected by a piece of **straight** tubing or pipe. The tubing or pipe should not exceed **two** feet, and it should be sized to maintain high refrigerant velocities. Elbows located between the TEV and distributor hinder proper distribution, and are **not** recommended.

The distributor can be positioned in any direction. If the system operates over widely varying conditions, best performance is usually obtained when the distributor feeds vertically upward or downward, see Figure 4. For applications where the distributor is not mounted directly to the TEV, the vertical feed arrangement is recommended.

Plugging one or more distributor outlets is not recommended because it ordinarily results in poor distribution. If it is absolutely necessary to plug circuits, it should be done symmetrically.

For applications requiring hot gas bypass, hot gas defrost, or reverse cycle defrost, the Sporlan 1650 series distributor can be used. This type of distributor is available with one or two side connections. Refer to pages 20-23 for further information. Standard type Sporlan distributors can be used for the above applications if used with a Sporlan auxiliary side connector (ASC). Refer to page 24 for further information.

THERMOSTATIC EXPANSION VALVE SELECTION

When selecting a thermostatic expansion valve (TEV) for use with a Sporlan type distributor, an **externally equal-**

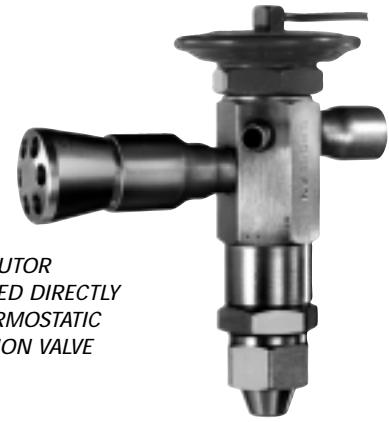

DISTRIBUTOR
MOUNTED DIRECTLY
TO THERMOSTATIC
EXPANSION VALVE

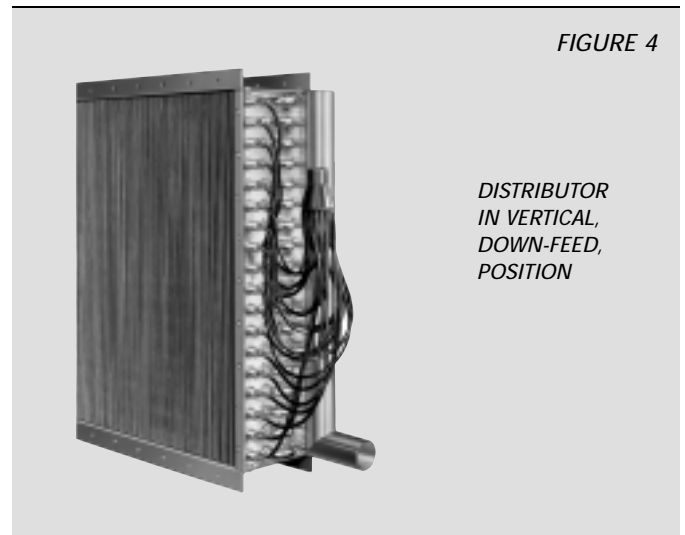

DISTRIBUTOR
IN VERTICAL,
DOWN-FEED,
POSITION

ized valve must be used to compensate for the distributor pressure drop. The distributor pressure drop also reduces the available pressure drop across the valve. As a result, the distributor pressure drop must be estimated before selecting the TEV. The distributor selection example on pages 7 and 8 provides the proper method for estimating distributor pressure drop.

When a system uses two or more distributors, each distributor must be fed by its own TEV. If one valve feeds two distributors, the refrigerant flow will not be divided evenly into the distributors.

BRAZING, TESTING, and INSTALLATION PROCEDURES

Brazing is a technique for joining metals with the use of a filler metal. The metals are heated above 800°F. The filler metal melts below the melting temperature of the metals being joined. Many brazing applications require a flux to remove oxides on the metal surfaces of the joint, and to prevent oxidation during the brazing process.

Sporlan brass body distributors are machined from either #360 brass rod or #377 brass forgings. Refer to page 9 for a list of the materials used to manufacture the distributors in this bulletin. Since distributor tubes are typically copper, as is the outlet fitting of the TEV, the majority of brazed distributor connections are brass to copper.

For a brass to copper connection, a flux must normally be used. The flux should be applied sparingly to the male end of the connection. The distributor body should be uniformly heated prior to applying the filler metal to the joint. For large, brass distributors, preheat the body before soldering. Large, brass distributor bodies are more prone to stress-cracking. Heating large brass distributor bodies quickly creates steep thermal gradients, stressing the brass. After brazing, allow the distributor to cool slowly. Quenching a hot distributor can crack it.

Avoid overheating brass distributor bodies, particularly the larger distributors. Overheating causes the zinc portion of the brass to migrate toward the surface of the distributor body. This leaves passageways in the brass for refrigerant leakage.

Phos/copper or silver/phos/copper (BCuP class) filler metals are suitable for most brass to copper connections. Silver (BAg class) filler metals can also be used. Please refer to manufacturers of filler metals for additional information on this subject.

Appropriate low temperature solders (e.g., Stay-Brite® from J. W. Harris) may also be used to install the distributor. The advantage of this type of solder is the reduced possibility of overheating the distributor or TEV body. One useful approach is brazing the distributor tubes to the distributor, and using a low temperature solder to connect the distributor and TEV. With a small body distributor, this practice reduces the possibility of accidentally undoing the distributor tube joints, or overheating the TEV body.

On replaceable nozzle type distributors, a visual inspection can be made after the distributor tubes are soldered in place. By removing the nozzle, restrictions in the tubing or distributor, as a result of the soldering, can be visually located or identified by use of a wire probe or an air jet.

When soldering tubes to the evaporator coil, extend the tubes into the coil far enough to prevent coil plugging from excess solder.

A leak check of the coil will not reveal a plugged circuit. Therefore, each circuit should be individually checked

with a probe wire or an air jet. A flow meter strategically placed can detect a restricted circuit.

The typical method to leak check an evaporator coil is to submerge the coil under water and administer pressure. If the TEV is mounted on the coil, excessive test pressure should not be used in leak testing the coil. Refer to Bulletin 10-11 for maximum allowable low side pressures for Sporlan TEVs. If the test pressure exceeds these limits, the external equalizer line of the expansion valve can be disconnected and left open to atmosphere above the water level. This procedure prevents test pressure from reaching the valve diaphragm.

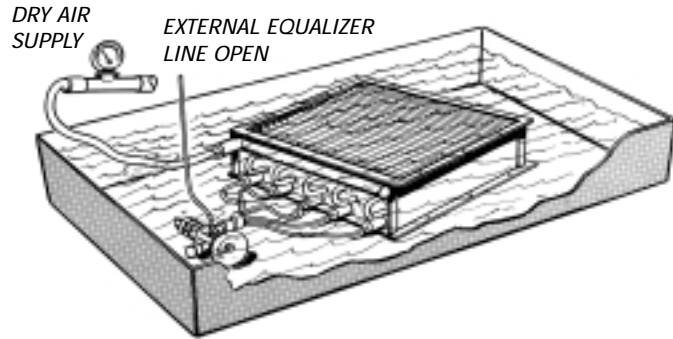

Exercise caution when soldering the TEV to the distributor. Direct the flame away from the valve body to avoid overheating it. As an extra precaution, a wet cloth should be wrapped around the valve body and thermostatic element during the soldering operation.



TEST EACH CIRCUIT

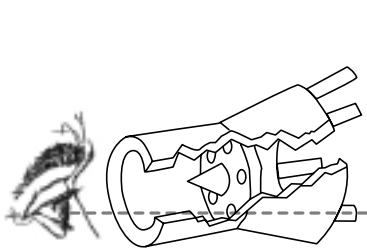

■ VISUAL

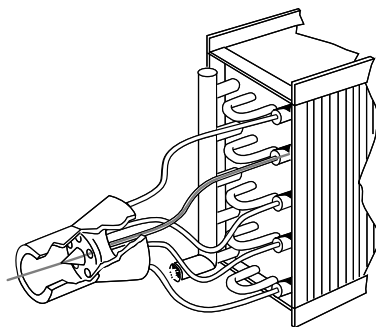

■ PROBE WIRE

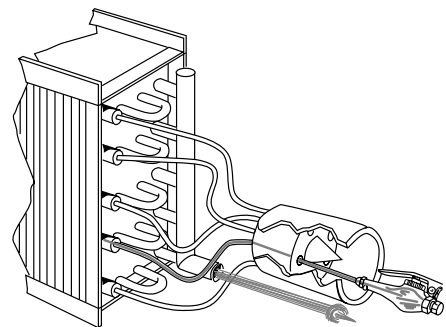

■ AIR JET

The nozzle and retainer ring for each replaceable nozzle type distributor are identified with a code letter. The nozzles and retainer rings with the same letter are physically interchangeable. The code letter, along with the available nozzle orifice numbers, are shown in the distributor specification tables.

SIMPLIFIED NOZZLE REMOVAL

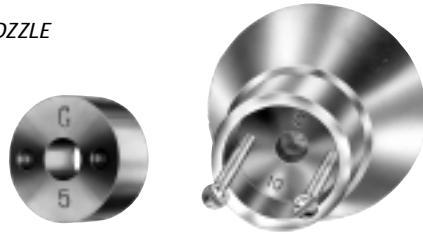

With the exception of the size L nozzle, all nozzles have two drilled and tapped holes to aid in removal. See table below for the thread size. This table is also applicable to the stainless steel nozzles used with Sporlan steel distributors for ammonia applications.

NOZZLE	EXTRACTION HOLE (Thread Size)
J, JR	4-40
G, GR, E, ER, C, CR, A, AR	6-32

SELECTION and ORDERING PROCEDURE

For uniform refrigerant distribution, the distributor tubes and distributor nozzle orifice must be correctly sized. Use the following procedure:

- Select Distributor Tube Size**—Divide the total load by the number of evaporator circuits. This provides the load per circuit in tons of refrigeration. Using Table A, page 10, select a distributor tube size with a capacity approximately equal to the load per circuit at the desired evaporator temperature. Be sure to multiply the tube rating, shown in the table, by the refrigerant liquid temperature correction factor and/or the distributor tube length correction factor, page 10, if either applies. The distributor tube ratings are based on a 100°F liquid temperature (86°F for R-717 applications) and 30 inch tube lengths.

The actual tube loading, as a percent of the published rating, is determined by dividing the actual load per circuit, by the published tube rating, corrected for liquid refrigerant temperature and distributor tube length. The pressure drop across the distributor tubes is determined using Table C, page 13. The calculated value should fall between 50% and 200%. A 10 psi pressure drop across the distributor tubes equates to 100% tube loading, and is the normal sizing recommendation.

Example:

- R-22
- 40°F evaporating temperature
- 90°F liquid refrigerant temperature
- 8 circuits, 24" tube lengths
- 10 tons

- Select a tube size and determine pressure drop across the tubes.
- Tons per circuit: 10/8 = 1.25 tons
- 1/4" OD tube rating in Table A: 1.14 tons
- Tube rating corrected for liquid refrigerant temperature and tube length: 1.14 x 1.17 x 1.07 = 1.43 tons
- Actual load as percentage of published rating: 1.25/1.43 = 0.87 or 87%
- Pressure drop across tubes from Table C: 8 psi

- Select Distributor Model**—Using the specification tables in this bulletin, select the distributor body style that accommodates the tube size selected, the number of circuits, and the TEV outlet size. The specification tables list the number of circuits and tubing sizes for each distributor. Contact Sporlan Valve Company regarding applications requiring special type distributors.

SPECIFICATION TABLES FOR NON-AMMONIA TYPE DISTRIBUTORS

- Brass - SAE flare models Pages 14, 15
- Brass - ODF solder models Pages 16, 17
- Brass - Flange models Page 18
- Aluminum - Flange models Page 19
- Brass - SAE flare and ODF solder side connection models Pages 22, 23

SPECIFICATION TABLES FOR R-717 (AMMONIA) TYPE DISTRIBUTORS

- Steel or Aluminum - Flange models . . . Page 26, 27

In the above example, the Type 1113 distributor may be used.

- Select Distributor Nozzle**—Using Table B, page 11, select an orifice number with a capacity approximately equal to the total system load at the desired evaporator temperature. Be sure to multiply the nozzle rating, shown in Table B, by the appropriate refrigerant liquid temperature correction factor, page 10. The distributor tube length correction factors do not apply with nozzle ratings.

The actual nozzle loading, as a percent of the published rating, is determined by dividing the actual system load by the published nozzle rating, corrected for refrigerant liquid temperature. The pressure across the nozzle is determined using Table C, page 13. The calculated value should fall between 50% and 200%.

Example:

- R-22
- 40°F evaporating temperature
- 90°F liquid refrigerant temperature
- 8 circuits, 24" tube lengths
- 10 tons
- Total system capacity: 10 tons
- #6 nozzle rating in Table B: 7.28 tons

- Nozzle rating corrected for refrigerant temperature: $7.28 \times 1.17 = 8.52$ tons
- Actual load as percentage of published rating: $10/8.52 = 1.17$ or 117%
- Pressure drop across nozzle from Table C: 35 psi
- Total pressure drop across distributor: $35 + 8 = 43$ psi
- Suggested distributor: 1113-8-1/4-6

Table 1 on page 8 lists the designations for replaceable type nozzles and the distributors they are used with. Table 2 on page 9 lists distributors using nonreplaceable nozzles.

Nonreplaceable nozzles do not carry a letter designation, and their orifice number is stamped on the distributor body.

The nozzle orifice number itself does not imply a specific capacity rating.

NOZZLE IDENTIFICATION

The nozzles have several different outside diameters. The sizes are designated by a letter code. Each nozzle is interchangeable between certain distributor bodies. For replaceable type nozzles, except the Type L, both the orifice number and letter are stamped on the nozzle. For the Type L nozzle, only the orifice number is stamped on the nozzle.

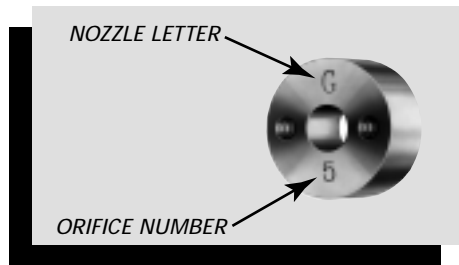

OEM CONSIDERATIONS

Often manufacturers of evaporator coils design and apply their coils to systems using different refrigerants, and operating at various evaporating temperatures and load conditions. For these applications, the replaceable nozzle type distributor has distinct benefits.

The distributor, without the nozzle, can be installed on the evaporator coil during coil production. The nozzle is added to the distributor once the coil application has been specified. Alternatively, assorted nozzles can be shipped with the coil. Instructions on how to select the correct nozzle would need to be sent with the assorted nozzles.

If the manufacturer prefers to install the nozzle during production, a satisfactory nozzle can often be selected to meet the majority of the coil applications.

DISTRIBUTOR QUICK REFERENCE GUIDE — Removeable Nozzles

TABLE 1

REFRIGERANT DISTRIBUTORS								
CONNECTION TYPE	TEV MODEL (1)	DISTRIBUTOR TYPE	MAXIMUM NO. OF CIRCUITS				NOZZLE TYPE	MATERIAL
			3/16	1/4	5/16	3/8		
1/2 SAE	BF,C,F,G,NI,Q,RI,RC <i>BI,FB,I,X</i>	1605	6	4	---	---	L	#360 BRASS
		1608	9	6	4	---		
5/8 SAE	C <i>BI,FB,I,X</i>	1104	7	6	---	---	J	
		1147	9	7	5	---		
1/2 ODM	EBF,EF,EG,EQ,RC RI,SBF,SQ, <i>BI,FB,I,X</i>	D260	6	4	---	---	L	
		D262	9	6	4	---		
5/8 ODM	EBF,EQ,RC,RI,S SBF, <i>BI,FB,I,X</i>	1620	6	4	---	---	J	
		1622	9	7	4	---		
7/8 ODM	EBS,EQ,O,S <i>BI,I,X</i>	1112	7	6	4	2	G	
		1113	12	8	6	4		
1-1/8 ODM	EBS,O,S X	1115	15	10	9	6	E	
		1116	20	15	---	---		
1-3/8 ODM	EBS,O	1117	18	15	9	7	C	
		1126	24	18	15	12		
		1128	28	25	21	16		
1-5/8 ODM	O	1125	28	24	20	16	A	
		1127	37	30	26	20		
		1143	40	36	30	24		
TYPE H VALVE FLANGE	H	1109	10	8	6	4	G	#360 BRASS
		1124	30	23	18	15	E	
		1192	11	10	6	6	G	
TYPE M/V VALVE FLANGE	M,V	1121	34	24	20	16	C	6061-T6 ALUMINUM
		1193	26	21	18	16		#360 BRASS
								6061-T6 ALUMINUM

(1) TEV models in italics are OEM-type thermostatic expansion valves.

TABLE 1 Continued

SIDE CONNECTION TYPE DISTRIBUTORS									
CONNECTION TYPE	TEV MODEL (1)	DISTRIBUTOR TYPE	MAXIMUM NO. OF CIRCUITS				NOZZLE TYPE	SIDE CONNECTION	MATERIAL
			3/16	1/4	5/16	3/8			
5/8 ODM	<i>EBF, EQ, RC, RI, S</i> <i>SBF, BI, FB, I, X</i>	1651(R)	7	5	---	---	J(R)	3/8 or 1/2 ODF	#360 BRASS
7/8 ODM	<i>EBS, EQ, O, S</i> <i>BI, I, X</i>	1653(R)	12	9	6	4	G(R)		
1-1/8 ODM	<i>EBS, O, S</i> <i>X</i>	1655(R)	20	12	10	7	E(R)	1/2 or 5/8 ODF	
1-3/8 ODM	<i>EBS, O</i>	1657(R)	26	18	14	11	C(R)	5/8 or 7/8 ODF	
1-5/8 ODM	<i>O</i>	1659(R)	32	24	18	14	A(R)	7/8 or 1-1/8 ODF	

AMMONIA DISTRIBUTORS									
CONNECTION TYPE	TEV MODEL	DISTRIBUTOR TYPE	MAXIMUM NO. OF CIRCUITS				NOZZLE TYPE	MATERIAL	
			3/16	1/4	5/16	1/8 PIPE			
TYPE D VALVE FLANGE	D	1132	5	4	3	---	GS	C-1018 or C-1019 STEEL	
		1130	10	10	6	6			
		1133 (2)	10	8	6	6			
		1180	8	6	---	---		6061-T6 ALUMINUM	
		1182	12	10	---	---			
TYPE A VALVE FLANGE	A	1138	19	14	12	10	CS	8620 STEEL	
		1185	20	16	11	---		6061-T6 ALUMINUM	

DISTRIBUTOR QUICK REFERENCE GUIDE — Permanent Nozzles**TABLE 2**

REFRIGERANT DISTRIBUTORS WITH PERMANENT NOZZLE									
CONNECTION TYPE	TEV MODEL (1)	DISTRIBUTOR TYPE	MAXIMUM NO. OF CIRCUITS				MATERIAL		
			3/16	1/4	5/16	3/8			
1/2 SAE	<i>BF, C, F, G, NI, Q, RC, RI</i> <i>BI, FB, I, X</i>	1603	6	4	---	---	#360 BRASS		
		1606	8	6	4	---			
0.43 ODM	<i>EBF, EF, EG, EQ, RC</i> <i>RI, SBF, SQ, BI, FB, I, X</i>	1604	6	4	---	---			
		1607	8	6	4	---			

SIDE CONNECTION TYPE DISTRIBUTORS WITH PERMANENT NOZZLE									
CONNECTION TYPE	TEV MODEL (1)	DISTRIBUTOR TYPE	MAXIMUM NO. OF CIRCUITS				SIDE CONNECTION	MATERIAL	
			3/16	1/4	5/16	3/8			
1/2 SAE	<i>BF, C, F, G, NI, Q, RC, RI</i> <i>BI, FB, I, X</i>	1650(R)	7	5	---	--	3/8 or 1/2 ODF	#360 BRASS	
5/8 SAE	C <i>BI, I, X</i>	1652(R)	7	4	---	---			
		1654(R)	12	9	6	4	1/2 or 5/8 ODF		
		1656(R)	20	12	10	7			

QUICK REFERENCE GUIDE — Replacing Obsolete Distributors**TABLE 3**

OBSOLETE REFRIGERANT DISTRIBUTORS									
CONNECTION SIZE	DISTRIBUTOR TYPE	MAXIMUM NO. OF CIRCUITS				NOZZLE TYPE	REPLACEMENT DISTRIBUTOR		
		3/16	1/4	5/16	3/8				
5/8 SAE	1103	4	3	---	---	J	1104		
5/8 ODM	1102	4	3	---	---		1620		
5/8 ODF	1105	7	6	---	---		1622 (4)		
1-1/8 ODM	1111	---	8	6	4	G	1115		
TYPE H VALVE FLANGE	1107 (3)	9	8	6	4		1109		
	1108 (3)	7	6	4	2		1124		
	1110	12	10	7	6		1192		
	1190 (3)	8	6	5	4				
TYPE M/V VALVE FLANGE	1119	16	12	9	7	C	1121		

(1) TEV models in italics are OEM-type thermostatic expansion valves.

(2) Side connection type ammonia distributor, one 3/8" or 1/2" FPT side connection available.

(3) Uses old Type H valve male flange (1.099" OD x 0.776" ID). Use K-1178 adaptor kit to connect to current Type H valve.

(4) Requires adaptation.

DISTRIBUTOR CAPACITIES

Distributor Tube Capacities – Tons of Refrigeration

TABLE A

R-12 and Replacement Refrigerants 134a, 401A, 401B, 409A (5)

DISTRIBUTOR TUBE OD - Inches	REFRIGERANT																			
	12				134a				401A				401B				409A			
	EVAPORATOR TEMPERATURE (°F)																			
	40°	20°	0°	-20°	40°	20°	0°	-20°	40°	20°	0°	-20°	40°	20°	0°	-20°	40°	20°	0°	-20°
3/16	0.28	0.20	0.16	0.12	0.30	0.21	0.16	0.12	0.33	0.26	0.20	0.16	0.34	0.26	0.20	0.16	0.27	0.20	0.16	0.12
1/4	0.80	0.59	0.45	0.35	0.85	0.62	0.47	0.36	0.96	0.73	0.57	0.46	0.96	0.74	0.58	0.47	0.77	0.58	0.45	0.36
5/16	1.62	1.20	0.91	0.71	1.73	1.26	0.95	0.73	1.94	1.48	1.16	0.93	1.95	1.50	1.18	0.94	1.57	1.19	0.92	0.72
3/8	2.92	2.16	1.64	1.27	3.12	2.27	1.71	1.32	3.47	2.65	2.07	1.66	3.51	2.69	2.10	1.69	2.84	2.14	1.65	1.30

R-22 and Replacement Refrigerants 407C (6), 410A (9)

DISTRIBUTOR TUBE OD - Inches	REFRIGERANT														
	22				407C					410A					
	EVAPORATOR TEMPERATURE (°F)														
	40°	20°	0°	-20°	-40°	40°	20°	0°	-20°	-40°	40°	20°	0°	-20°	-40°
3/16	0.40	0.30	0.23	0.18	0.14	0.32	0.23	0.18	0.14	0.11	0.42	0.31	0.23	0.18	0.14
1/4	1.15	0.86	0.66	0.51	0.40	0.91	0.68	0.51	0.40	0.31	1.21	0.90	0.68	0.52	0.40
5/16	2.33	1.75	1.34	1.04	0.82	1.86	1.38	1.05	0.80	0.63	2.46	1.83	1.39	1.06	0.81
3/8	4.21	3.16	2.42	1.88	1.48	3.36	2.50	1.89	1.45	1.14	4.44	3.32	2.51	1.91	1.47

R-502 Replacement Refrigerants 402A, 402B, 404A, 407A (6)

DISTRIBUTOR TUBE OD - Inches	REFRIGERANT																			
	402A				402B					404A				407A						
	EVAPORATOR TEMPERATURE (°F)																			
	40°	20°	0°	-20°	-40°	40°	20°	0°	-20°	-40°	40°	20°	0°	-20°	-40°	40°	20°	0°	-20°	-40°
3/16	0.28	0.20	0.15	0.12	0.09	0.32	0.23	0.18	0.13	0.11	0.28	0.21	0.15	0.12	0.09	0.34	0.25	0.19	0.14	0.11
1/4	0.80	0.59	0.44	0.33	0.26	0.91	0.68	0.51	0.39	0.31	0.82	0.59	0.44	0.33	0.26	0.99	0.72	0.54	0.41	0.32
5/16	1.63	1.20	0.90	0.68	0.52	1.86	1.38	1.04	0.79	0.62	1.66	1.21	0.90	0.68	0.52	2.02	1.48	1.10	0.83	0.65
3/8	2.95	2.17	1.62	1.22	0.94	3.36	2.49	1.87	1.43	1.12	3.00	2.19	1.62	1.22	0.94	3.66	2.68	2.00	1.51	1.17

R-502 and Replacement Refrigerants 408A, 507 (6)

DISTRIBUTOR TUBE OD - Inches	REFRIGERANT														
	408A					502					507				
	EVAPORATOR TEMPERATURE (°F)														
	40°	20°	0°	-20°	-40°	40°	20°	0°	-20°	-40°	40°	20°	0°	-20°	-40°
3/16	0.37	0.27	0.21	0.16	0.12	0.27	0.20	0.15	0.11	0.09	0.28	0.20	0.15	0.11	0.09
1/4	1.07	0.79	0.60	0.46	0.36	0.78	0.58	0.43	0.33	0.25	0.81	0.59	0.44	0.33	0.25
5/16	2.18	1.61	1.22	0.93	0.72	1.58	1.17	0.88	0.67	0.52	1.65	1.21	0.89	0.67	0.50
3/8	3.94	2.92	2.20	1.68	1.30	2.86	2.12	1.59	1.21	0.93	2.99	2.18	1.61	1.20	0.91

R-717 (7)

DISTRIBUTOR TUBE OD - Inches	REFRIGERANT					
	717 (Ammonia)					
	EVAPORATOR TEMPERATURE (°F)					
	40°	20°	5°	-10°	-20°	-30°
3/16	1.79	1.27	1.01	0.82	0.72	0.64
1/4	4.52	3.20	2.55	2.07	1.82	1.62
5/16	9.73	6.90	5.50	4.46	3.93	3.49
1/8" Pipe*	12.0	8.50	6.77	5.50	4.84	4.30

*Schedule 40

Correction Factors for Other Liquid Temperatures for Nozzle and Tubes (8)

LIQUID TEMPERATURE °F	50°	60°	70°	80°	90°	100°	110°	120°
CORRECTION FACTOR	2.10	1.83	1.59	1.37	1.17	1.00	0.85	0.72

Correction Factors for Other Distributor Tube Lengths

TUBE LENGTH - Inches	12	18	24	30	36	42	48	54	60	66	72
CORRECTION FACTOR	1.36	1.16	1.07	1.00	0.95	0.90	0.86	0.82	0.79	0.76	0.73

(5) Ratings based on 100°F liquid entering TEV, 15 psi ΔP across nozzle, 10 psi ΔP across distributor tubes, 30" tube length.

(6) Ratings based on 100°F liquid entering TEV, 25 psi ΔP across nozzle, 10 psi ΔP across distributor tubes, 30" tube length.

(7) Ratings based on 86°F liquid entering TEV, 30 psi ΔP across nozzle, 10 psi ΔP across distributor tubes, 30" tube length.

(8) For direct expansion applications with liquid temperatures lower than tabulated values or for flooded liquid recirculation systems - Contact Sporlan Valve Co.

For information on applications and capacities at evaporator temperatures below minus 40°F, consult Sporlan Valve Company.

(9) Ratings based on 100°F liquid entering TEV, 35 psi ΔP across nozzle, 10 psi ΔP across distributor tubes, 30" tube length.

DISTRIBUTOR CAPACITIES

Distributor Nozzle Capacities – Tons of Refrigeration

TABLE B

R-12 and Replacement Refrigerants 134a, 401A, 401B, 409A ⁽⁵⁾

DISTRIBUTOR NOZZLE NUMBER	REFRIGERANT																			
	12				134a				401A				401B				409A			
	EVAPORATOR TEMPERATURE (°F)																			
	40°	20°	0°	-20°	40°	20°	0°	-20°	40°	20°	0°	-20°	40°	20°	0°	-20°	40°	20°	0°	-20°
1/9	0.07	0.06	0.05	0.04	0.08	0.06	0.05	0.04	0.08	0.06	0.05	0.04	0.08	0.06	0.05	0.04	0.07	0.06	0.04	0.04
1/6	0.11	0.09	0.07	0.06	0.12	0.09	0.07	0.06	0.13	0.10	0.08	0.07	0.13	0.10	0.08	0.07	0.11	0.09	0.07	0.06
1/4	0.18	0.14	0.11	0.09	0.20	0.15	0.12	0.10	0.20	0.16	0.13	0.11	0.20	0.16	0.13	0.11	0.17	0.14	0.11	0.09
1/3	0.24	0.18	0.15	0.12	0.26	0.20	0.15	0.13	0.26	0.20	0.17	0.14	0.27	0.21	0.17	0.14	0.23	0.18	0.15	0.12
1/2	0.33	0.25	0.20	0.17	0.36	0.27	0.21	0.17	0.36	0.28	0.23	0.19	0.37	0.29	0.23	0.19	0.31	0.25	0.20	0.17
3/4	0.50	0.38	0.30	0.25	0.54	0.41	0.32	0.26	0.55	0.43	0.34	0.29	0.56	0.43	0.35	0.29	0.48	0.37	0.30	0.25
1	0.67	0.51	0.41	0.33	0.72	0.54	0.43	0.35	0.74	0.57	0.46	0.38	0.75	0.58	0.47	0.39	0.64	0.50	0.40	0.34
1-1/2	0.98	0.74	0.59	0.48	1.05	0.79	0.63	0.51	1.07	0.83	0.67	0.56	1.09	0.84	0.68	0.57	0.92	0.73	0.59	0.49
2	1.34	1.02	0.81	0.66	1.44	1.09	0.86	0.70	1.47	1.14	0.92	0.77	1.49	1.16	0.93	0.78	1.27	1.00	0.81	0.68
2-1/2	1.67	1.27	1.01	0.83	1.79	1.35	1.07	0.88	1.83	1.42	1.15	0.96	1.86	1.44	1.16	0.97	1.58	1.24	1.01	0.84
3	2.01	1.53	1.21	0.99	2.15	1.63	1.28	1.05	2.20	1.70	1.38	1.15	2.23	1.73	1.40	1.16	1.90	1.49	1.21	1.01
4	2.69	2.05	1.62	1.33	2.88	2.18	1.72	1.41	2.94	2.28	1.84	1.54	2.99	2.32	1.87	1.55	2.54	2.00	1.62	1.35
5	3.32	2.53	2.00	1.64	3.55	2.68	2.12	1.74	3.63	2.81	2.27	1.89	3.69	2.86	2.31	1.92	3.13	2.46	2.00	1.67
6	3.98	3.03	2.40	1.97	4.26	3.22	2.54	2.08	4.35	3.37	2.72	2.27	4.42	3.43	2.76	2.30	3.76	2.95	2.39	2.00
8	4.79	3.65	2.89	2.37	5.13	3.88	3.06	2.51	5.24	4.06	3.28	2.73	5.33	4.13	3.33	2.77	4.53	3.55	2.88	2.41
10	5.37	4.09	3.24	2.66	5.75	4.35	3.43	2.81	5.87	4.55	3.68	3.06	5.97	4.63	3.73	3.10	5.07	3.98	3.23	2.70
12	6.63	5.05	4.00	3.28	7.10	5.37	4.24	3.47	7.25	5.62	4.54	3.78	7.38	5.72	4.61	3.83	6.27	4.92	3.99	3.33
15	8.22	6.26	4.97	4.07	8.81	6.65	5.25	4.30	8.99	6.97	5.63	4.69	9.15	7.09	5.72	4.75	7.77	6.10	4.95	4.13
17	9.20	7.00	5.55	4.55	9.85	7.44	5.87	4.81	10.1	7.79	6.30	5.25	10.2	7.93	6.39	5.31	8.69	6.82	5.53	4.62
20	11.1	8.44	6.69	5.48	11.9	8.97	7.08	5.80	12.1	9.39	7.59	6.33	12.3	9.55	7.70	6.40	10.5	8.22	6.67	5.57
25	13.9	10.6	8.42	6.90	14.9	11.3	8.91	7.30	15.2	11.8	9.55	7.96	15.5	12.0	9.69	8.05	13.2	10.3	8.38	7.01
30	15.9	12.1	9.62	7.88	17.1	12.9	10.2	8.33	17.4	13.5	10.9	9.09	17.7	13.7	11.1	9.20	15.1	11.8	9.58	8.00
35	19.2	14.6	11.6	9.48	20.5	15.5	12.2	10.0	21.0	16.2	13.1	10.9	21.3	16.5	13.3	11.1	18.1	14.2	11.5	9.63
40	21.5	16.4	13.0	10.6	23.0	17.4	13.7	11.2	23.5	18.2	14.7	12.3	23.9	18.5	14.9	12.4	20.3	15.9	12.9	10.8
50	27.9	21.2	16.8	13.8	29.9	22.5	17.8	14.6	30.5	23.6	19.1	15.9	31.0	24.0	19.4	16.1	26.3	20.7	16.8	14.0

R-22 and Replacement Refrigerant 407C ⁽⁶⁾, 410A ⁽⁹⁾

DISTRIBUTOR NOZZLE NUMBER	REFRIGERANT														
	22					407C					410A				
	EVAPORATOR TEMPERATURE (°F)														
	40°	20°	0°	-20°	-40°	40°	20°	0°	-20°	-40°	40°	20°	0°	-20°	-40°
1/9	0.14	0.11	0.09	0.07	0.06	0.11	0.08	0.07	0.06	0.05	0.16	0.13	0.10	0.08	0.07
1/6	0.21	0.16	0.13	0.11	0.09	0.17	0.13	0.10	0.09	0.07	0.25	0.20	0.16	0.13	0.11
1/4	0.34	0.26	0.21	0.18	0.15	0.27	0.21	0.17	0.14	0.12	0.40	0.31	0.25	0.21	0.17
1/3	0.44	0.34	0.28	0.23	0.20	0.35	0.27	0.22	0.18	0.15	0.53	0.41	0.33	0.27	0.23
1/2	0.61	0.48	0.38	0.32	0.27	0.48	0.38	0.30	0.25	0.21	0.73	0.57	0.46	0.37	0.31
3/4	0.92	0.72	0.58	0.48	0.41	0.73	0.57	0.46	0.38	0.32	1.10	0.86	0.69	0.57	0.47
1	1.23	0.96	0.78	0.64	0.55	0.97	0.76	0.61	0.50	0.43	1.47	1.15	0.92	0.76	0.64
1-1/2	1.79	1.40	1.13	0.94	0.80	1.41	1.10	0.89	0.73	0.62	2.14	1.67	1.34	1.10	0.92
2	2.46	1.92	1.55	1.29	1.10	1.94	1.51	1.22	1.01	0.86	2.93	2.30	1.84	1.51	1.27
2-1/2	3.07	2.39	1.93	1.60	1.37	2.42	1.89	1.52	1.25	1.07	3.66	2.86	2.30	1.88	1.58
3	3.68	2.87	2.32	1.93	1.65	2.90	2.26	1.82	1.50	1.28	4.39	3.44	2.76	2.26	1.90
4	4.92	3.84	3.10	2.58	2.20	3.88	3.03	2.44	2.01	1.71	5.88	4.60	3.69	3.02	2.54
5	6.07	4.74	3.83	3.18	2.72	4.79	3.74	3.01	2.48	2.11	7.25	5.67	4.55	3.73	3.13
6	7.28	5.68	4.59	3.81	3.26	5.74	4.48	3.60	2.98	2.53	8.69	6.80	5.45	4.47	3.76
8	8.77	6.84	5.52	4.59	3.93	6.91	5.40	4.34	3.59	3.05	10.5	8.19	6.57	5.39	4.53
10	9.83	7.67	6.19	5.15	4.40	7.75	6.05	4.86	4.02	3.42	11.7	9.18	7.36	6.04	5.07
12	12.1	9.47	7.65	6.36	5.43	9.57	7.47	6.01	4.97	4.22	14.5	11.3	9.09	7.46	6.26
15	15.1	11.7	9.48	7.88	6.74	11.9	9.27	7.45	6.16	5.24	18.0	14.1	11.3	9.25	7.77
17	16.8	13.1	10.6	8.81	7.54	13.3	10.4	8.33	6.89	5.86	20.1	15.7	12.6	10.3	8.69
20	20.3	15.8	12.8	10.6	9.08	16.0	12.5	10.0	8.30	7.06	24.2	19.0	15.2	12.5	10.5
25	25.5	19.9	16.1	13.4	11.4	20.1	15.7	12.6	10.4	8.88	30.5	23.8	19.1	15.7	13.2
30	29.2	22.8	18.4	15.3	13.1	23.0	17.9	14.4	11.9	10.1	34.8	27.2	21.8	17.9	15.0
35	35.1	27.4	22.1	18.4	15.7	27.6	21.6	17.4	14.3	12.2	41.9	32.8	26.3	21.5	18.1
40	39.3	30.7	24.8	20.6	17.6	31.0	24.2	19.5	16.1	13.7	47.0	36.8	29.5	24.2	20.3
50	51.0	39.8	32.1	26.7	22.8	40.2	31.4	25.2	20.9	17.7	60.9	47.7	38.2	31.3	26.3

(5) Ratings based on 100°F liquid entering TEV, 15 psi ΔP across nozzle, 10 psi ΔP across distributor tubes, 30" tube length.

(6) Ratings based on 100°F liquid entering TEV, 25 psi ΔP across nozzle, 10 psi ΔP across distributor tubes, 30" tube length.

(9) Ratings based on 100°F liquid entering TEV, 35 psi ΔP across nozzle, 10 psi ΔP across distributor tubes, 30" tube length.

DISTRIBUTOR CAPACITIES

Distributor Nozzle Capacities – Tons of Refrigeration

TABLE B Continued

R-502 Replacement Refrigerants 402A, 402B, 404A, 407A (6)

DISTRIBUTOR NOZZLE NUMBER	REFRIGERANT																			
	402A					402B					404A					407A				
	EVAPORATOR TEMPERATURE (°F)																			
	40°	20°	0°	-20°	-40°	40°	20°	0°	-20°	-40°	40°	20°	0°	-20°	-40°	40°	20°	0°	-20°	-40°
1/9	0.09	0.07	0.05	0.04	0.04	0.10	0.08	0.06	0.05	0.04	0.09	0.07	0.05	0.04	0.04	0.11	0.09	0.07	0.06	0.05
1/6	0.14	0.11	0.08	0.07	0.05	0.16	0.12	0.10	0.08	0.07	0.14	0.11	0.08	0.07	0.05	0.17	0.13	0.11	0.09	0.07
1/4	0.22	0.17	0.13	0.11	0.09	0.26	0.20	0.16	0.13	0.11	0.23	0.17	0.13	0.11	0.09	0.28	0.22	0.17	0.14	0.12
1/3	0.29	0.22	0.17	0.14	0.11	0.33	0.26	0.21	0.17	0.14	0.30	0.23	0.18	0.14	0.11	0.36	0.28	0.22	0.18	0.15
1/2	0.40	0.31	0.24	0.19	0.16	0.46	0.36	0.28	0.23	0.19	0.41	0.31	0.24	0.19	0.16	0.50	0.39	0.31	0.25	0.21
3/4	0.60	0.46	0.36	0.29	0.24	0.70	0.54	0.43	0.35	0.29	0.62	0.47	0.37	0.29	0.24	0.76	0.59	0.47	0.38	0.32
1	0.81	0.62	0.48	0.39	0.32	0.93	0.72	0.57	0.47	0.39	0.83	0.63	0.49	0.39	0.32	1.02	0.79	0.63	0.51	0.43
1-1/2	1.17	0.90	0.70	0.56	0.46	1.36	1.05	0.83	0.68	0.56	1.20	0.92	0.71	0.57	0.46	1.48	1.14	0.91	0.74	0.62
2	1.61	1.23	0.97	0.77	0.63	1.86	1.44	1.14	0.93	0.77	1.65	1.26	0.98	0.78	0.64	2.03	1.57	1.25	1.02	0.86
2-1/2	2.00	1.54	1.20	0.96	0.78	2.32	1.80	1.43	1.16	0.96	2.06	1.57	1.22	0.97	0.79	2.54	1.96	1.56	1.27	1.07
3	2.41	1.84	1.44	1.16	0.94	2.79	2.15	1.71	1.39	1.15	2.47	1.88	1.47	1.17	0.95	3.04	2.35	1.87	1.52	1.28
4	3.22	2.47	1.93	1.55	1.26	3.73	2.88	2.29	1.86	1.54	3.31	2.52	1.96	1.56	1.27	4.07	3.15	2.50	2.04	1.71
5	3.97	3.04	2.39	1.91	1.55	4.60	3.56	2.82	2.29	1.90	4.08	3.11	2.42	1.93	1.57	5.02	3.88	3.08	2.52	2.11
6	4.76	3.65	2.86	2.29	1.86	5.52	4.27	3.39	2.75	2.28	4.89	3.72	2.91	2.31	1.88	6.02	4.65	3.70	3.02	2.53
8	5.74	4.39	3.44	2.76	2.24	6.64	5.14	4.08	3.31	2.74	5.89	4.49	3.50	2.79	2.27	7.25	5.61	4.45	3.64	3.05
10	6.43	4.93	3.86	3.09	2.52	7.45	5.76	4.57	3.71	3.08	6.60	5.03	3.92	3.12	2.54	8.13	6.28	4.99	4.08	3.42
12	7.94	6.08	4.77	3.81	3.11	9.20	7.11	5.64	4.59	3.80	8.16	6.21	4.84	3.86	3.14	10.0	7.76	6.17	5.03	4.22
15	9.85	7.54	5.91	4.73	3.85	11.4	8.82	7.00	5.69	4.71	10.1	7.70	6.01	4.78	3.89	12.5	9.62	7.65	6.24	5.24
17	11.0	8.44	6.61	5.29	4.31	12.8	9.86	7.83	6.36	5.27	11.3	8.61	6.72	5.35	4.35	13.9	10.8	8.55	6.98	5.86
20	13.3	10.2	7.97	6.37	5.19	15.4	11.9	9.43	7.66	6.35	13.6	10.4	8.10	6.45	5.24	16.8	13.0	10.3	8.41	7.06
25	16.7	12.8	10.0	8.02	6.53	19.3	15.0	11.9	9.64	7.99	17.1	13.1	10.2	8.11	6.60	21.1	16.3	13.0	10.6	8.88
30	19.1	14.6	11.5	9.16	7.46	22.1	17.1	13.6	11.0	9.12	19.6	14.9	11.6	9.27	7.54	24.0	18.6	14.8	12.1	10.1
35	22.9	17.6	13.8	11.0	8.98	26.6	20.5	16.3	13.3	11.0	23.6	17.9	14.0	11.1	9.07	29.0	22.4	17.8	14.5	12.2
40	25.7	19.7	15.4	12.4	10.1	29.8	23.0	18.3	14.9	12.3	26.4	20.1	15.7	12.5	10.2	32.5	25.1	20.0	16.3	13.7
50	33.4	25.6	20.0	16.0	13.1	38.6	29.9	23.7	19.3	16.0	34.3	26.1	20.4	16.2	13.2	42.2	32.6	25.9	21.1	17.7

R-502 and Replacement Refrigerants 408A, 507 (6)

DISTRIBUTOR NOZZLE NUMBER	REFRIGERANT														
	408A					502					507				
	EVAPORATOR TEMPERATURE (°F)														
	40°	20°	0°	-20°	-40°	40°	20°	0°	-20°	-40°	40°	20°	0°	-20°	-40°
1/9	0.12	0.10	0.08	0.06	0.05	0.09	0.07	0.05	0.04	0.04	0.09	0.07	0.05	0.04	0.03
1/6	0.19	0.15	0.12	0.10	0.08	0.14	0.11	0.08	0.07	0.06	0.14	0.11	0.08	0.07	0.05
1/4	0.30	0.24	0.19	0.15	0.13	0.22	0.17	0.13	0.11	0.09	0.23	0.17	0.13	0.11	0.09
1/3	0.40	0.31	0.25	0.20	0.17	0.29	0.22	0.17	0.14	0.12	0.29	0.22	0.17	0.14	0.11
1/2	0.55	0.43	0.34	0.28	0.23	0.40	0.31	0.24	0.20	0.16	0.41	0.31	0.24	0.19	0.16
3/4	0.83	0.64	0.51	0.42	0.35	0.61	0.46	0.36	0.29	0.24	0.61	0.47	0.36	0.29	0.23
1	1.11	0.86	0.69	0.56	0.47	0.81	0.62	0.49	0.39	0.33	0.82	0.62	0.49	0.39	0.31
1-1/2	1.62	1.25	1.00	0.81	0.68	1.18	0.90	0.71	0.57	0.47	1.20	0.91	0.71	0.56	0.46
2	2.22	1.72	1.37	1.12	0.94	1.62	1.24	0.97	0.79	0.65	1.64	1.25	0.97	0.77	0.62
2-1/2	2.77	2.14	1.71	1.39	1.17	2.02	1.54	1.22	0.98	0.81	2.05	1.56	1.21	0.96	0.78
3	3.33	2.57	2.05	1.67	1.40	2.42	1.85	1.46	1.18	0.97	2.46	1.87	1.45	1.15	0.93
4	4.46	3.44	2.74	2.24	1.88	3.24	2.48	1.95	1.57	1.30	3.29	2.50	1.94	1.54	1.25
5	5.50	4.25	3.38	2.76	2.31	3.99	3.06	2.41	1.94	1.60	4.06	3.08	2.40	1.90	1.54
6	6.59	5.09	4.05	3.31	2.77	4.79	3.66	2.89	2.33	1.92	4.86	3.69	2.87	2.28	1.85
8	7.94	6.13	4.88	3.99	3.34	5.77	4.41	3.48	2.80	2.31	5.86	4.45	3.46	2.75	2.23
10	8.90	6.88	5.47	4.47	3.74	6.47	4.95	3.90	3.14	2.59	6.57	4.99	3.88	3.08	2.50
12	11.0	8.49	6.76	5.52	4.62	7.98	6.11	4.81	3.88	3.20	8.11	6.16	4.79	3.80	3.08
15	13.6	10.5	8.38	6.84	5.73	9.90	7.58	5.97	4.81	3.97	10.1	7.64	5.94	4.72	3.83
17	15.2	11.8	9.37	7.65	6.41	11.1	8.47	6.67	5.38	4.44	11.2	8.54	6.64	5.27	4.28
20	18.4	14.2	11.3	9.22	7.73	13.3	10.2	8.04	6.49	5.35	13.6	10.3	8.01	6.36	5.16
25	23.1	17.8	14.2	11.6	9.72	16.8	12.8	10.1	8.16	6.73	17.1	12.9	10.1	8.00	6.48
30	26.4	20.4	16.2	13.3	11.1	19.2	14.7	11.6	9.32	7.69	19.5	14.8	11.5	9.13	7.41
35	31.7	24.5	19.5	15.9	13.4	23.1	17.7	13.9	11.2	9.26	23.4	17.8	13.8	11.0	8.91
40	35.6	27.5	21.9	17.9	15.0	25.9	19.8	15.6	12.6	10.4	26.3	20.0	15.5	12.3	9.99
50	46.2	35.7	28.4	23.2	19.4	33.6	25.7	20.2	16.3	13.5	34.1	25.9	20.1	16.0	13.0

(6) Ratings based on 100°F liquid entering TEV, 25 psi ΔP across nozzle, 10 psi ΔP across distributor tubes, 30" tube length.

TABLE B Continued

R-717 (7)

DISTRIBUTOR NOZZLE NUMBER	REFRIGERANT					
	717 (Ammonia)					
	EVAPORATOR TEMPERATURE (°F)					
	40°	20°	5°	-10°	-20°	-30°
1A	0.65	0.48	0.41	0.35	0.32	0.30
1-1/2A	1.07	0.79	0.66	0.58	0.53	0.50
2A	1.42	1.05	0.88	0.76	0.70	0.65
2-1/2A	2.03	1.50	1.26	1.09	1.00	0.94
3A	2.62	1.93	1.62	1.40	1.30	1.21
4A	3.01	2.22	1.86	1.61	1.49	1.39
5A	4.07	3.01	2.52	2.19	2.02	1.88
6A	4.95	3.66	3.07	2.66	2.45	2.29
8A	6.83	5.05	4.23	3.67	3.38	3.15
10A	8.10	5.98	5.02	4.35	4.01	3.74

DISTRIBUTOR NOZZLE NUMBER	REFRIGERANT					
	717 (Ammonia)					
	EVAPORATOR TEMPERATURE(°F)					
	40°	20°	5°	-10°	-20°	-30°
12A	9.64	7.12	5.98	5.17	4.77	4.45
15A	13.1	9.69	8.13	7.04	6.50	6.06
18A	16.3	12.1	10.1	8.77	8.09	7.55
20A	17.4	12.8	10.8	9.31	8.59	8.01
25A	22.2	16.4	13.7	11.9	11.0	10.2
30A	29.2	21.6	18.1	15.7	14.5	13.5
35A	34.8	25.7	21.6	18.7	17.2	16.1
40A	39.2	29.0	24.3	21.0	19.4	18.1
50A	49.5	36.6	30.7	26.6	24.5	22.9

(7) Ratings based on 86°F liquid entering TEV, 30 psi ΔP across nozzle, 10 psi ΔP across distributor tubes, 30" tube length.

PRESSURE DROP vs. DISTRIBUTOR LOADING

TABLE C

ACTUAL LOAD as a % of PUBLISHED RATING (Corrected for Liquid Temperature and/or Tube Length if Necessary)	REFRIGERANT							
	12, 134a, 401A, 401B, 409A		22, 402A, 402B, 404A, 407A, 407C, 408A, 502, 507		410A		717 (Ammonia)	
	ΔP NOZZLE (psi)	ΔP TUBES and PASSAGES (psi)	ΔP NOZZLE (psi)	ΔP TUBES and PASSAGES (psi)	ΔP NOZZLE (psi)	ΔP TUBES and PASSAGES (psi)	ΔP NOZZLE (psi)	ΔP TUBES and PASSAGES (psi)
50	4	3	7	3	12	3	11	3
60	6	4	10	4	17	4	15	4
70	8	5	13	5	21	6	19	5
80	10	6	16	6	26	7	23	6
90	12	8	20	8	30	9	26	8
100	15	10	25	10	35	10	30	10
110	18	12	30	12	40	12	33	12
120	20	14	35	14	44	13	36	13
130	22	16	38	16	49	15	39	15
140	24	18	40	18	53	16	42	16
150	27	21	43	21	58	18	46	18
160	29	23	46	24	62	20	49	19
170	31	25	49	27	67	21	52	21
180	33	27	52	30	71	23	54	22
190	36	29	54	32	76	25	56	24
200	38	31	57	34	80	26	59	25

See nozzle loading recommendation on pages 7 and 8 for operation on systems with capacity reductions.

ORDERING INSTRUCTIONS

Proper ordering instructions for any distributor comprises four items:

- **Distributor Type**
See Specification Tables, Pages 14 to 19, 22 to 27
- **Number of Circuits**
Depends on evaporator design
- **Size of Circuits**
See Table-A, Page 10, for 5/32" circuit capacity information, contact Sporlan Valve Company
- **Nozzle Orifice Number**
See Table-B, Page 11 & 12

Example:

A coil requires 16 circuits for .67 ton load per circuit at 0°F; R-22 evaporating temperature; total load 10.7 tons. Distributor order would read: One Distributor, Type 1126, with 16, 1/4 inch circuits and a 17 Nozzle Orifice Number, or simplified...

Quantity	Type	Number Circuits	Size Circuits	Nozzle Orifice Number
One	1126	16	1/4"	17

SPECIFICATIONS

SAE Flare Connections – Brass Body

The distributors listed on pages 14 and 15 are suitable for TEVs with 1/2" or 5/8" SAE male outlet connections, e.g., Sporlan types BF, C, F, G, MC, NI, and Q.

These distributors can also be applied to Sporlan OEM type thermostatic expansion valves having the same outlet connections. The distributor inlet is a standard 45° short flare nut, and complies with SAE standard J513f.

Material: body and flare nut - brass
inlet tube - copper

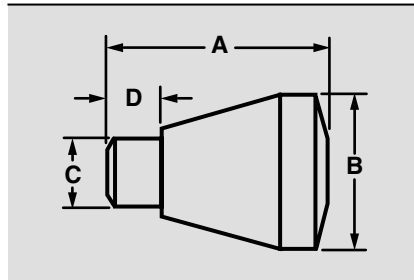
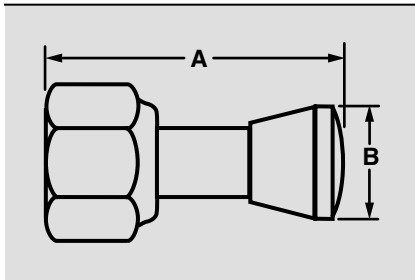

NO. CIRCUITS & TUBING SIZES AVAILABLE	NOZZLE ORIFICE NUMBERS AVAILABLE	NOZZLE	EXPANSION VALVE OUTLET CONNECTION Inches	DISTRIBUTORS	DIMENSIONS Inches				
					A	B	C	D	
TYPE 1603	Furnished with 1/2" OD copper tubing and standard short 1/2" SAE flare nut. Net Weight - Approximately 3 oz.					2.05	0.81	---	---
2 to 6 - 3/16"	1/9 thru 5	permanent not replaceable	1/2 SAE Flare						
2 to 4 - 1/4"									
TYPE 1604	*Same as Type 1603, except furnished less SAE flare nut and copper tubing. Net Weight - Approximately 1 oz.					0.97	0.81	.429 .430	0.33
2 to 6 - 3/16"	1/9 thru 5	permanent not replaceable	*						
2 to 4 - 1/4"									
TYPE 1606	Furnished with 1/2" OD copper tubing and standard short 1/2" SAE flare nut. Net Weight - Approximately 5 oz.					2.44	1.00	---	---
7 to 8 - 3/16"	1/9 thru 5	permanent not replaceable	1/2 SAE Flare						
5 to 6 - 1/4"									
2 to 4 - 5/16"									
TYPE 1607	*Same as Type 1606, except furnished less SAE flare nut and copper tubing. Net Weight - Approximately 3 oz.					1.36	1.00	.429 .430	0.33
7 to 8 - 3/16"	1/9 thru 5	permanent not replaceable	*						
5 to 6 - 1/4"									
2 to 4 - 5/16"									

To fulfill manufacturers' special requirements, additional distributors are available on quantity orders. Consult your Sporlan Sales Engineer or write Sporlan Valve Company. READ ORDERING INSTRUCTIONS page 13.

SPECIFICATIONS

SAE Flare Connections – Brass Body (continued)

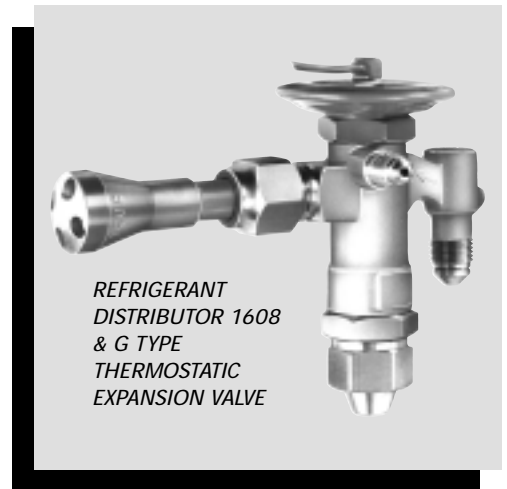
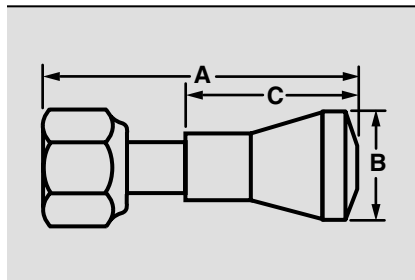

NO. CIRCUITS & TUBING SIZES AVAILABLE	NOZZLE ORIFICE NUMBERS AVAILABLE	NOZZLE & RETAINER RING SIZE	INLET CONNECTION Inches	DISTRIBUTOR	DIMENSIONS Inches		
					A	B	C
TYPE 1605					Net Weight - Approximately 3 oz.		
2 to 6 - 3/16"	1/9 thru 8	L	1/2 SAE Flare		2.46	0.81	1.44
2 to 4 - 1/4"							
TYPE 1608					Net Weight - Approximately 5 oz.		
2 to 9 - 3/16"	1/9 thru 8	L	1/2 SAE Flare		2.94	1.00	1.63
5 to 6 - 1/4"							
2 to 4 - 5/16"							
TYPE 1104					Net Weight - Approximately 8 oz.		
2 to 7 - 3/16"	1/9 thru 8	J	5/8 SAE Flare		3.13	0.91	1.78
2 to 6 - 1/4"							
TYPE 1147					Net Weight - Approximately 8 oz.		
2 to 9 - 3/16"	1/9 thru 8	J	5/8 SAE Flare		3.16	1.12	1.81
2 to 7 - 1/4"							
2 to 5 - 5/16"							

To fulfill manufacturers' special requirements, additional distributors are available on quantity orders. Consult your Sporlan Sales Engineer or write Sporlan Valve Company. READ ORDERING INSTRUCTIONS page 13.

Conversion Nozzle Kit

Sporlan's unique Conversion Nozzle Kit easily converts R-12 and R-502 supermarket cases to R-22 or another new refrigerant.

The hassle of replacing distributors in multi-circuited systems is eliminated. Simply disconnect the distributor from the expansion valve, insert the properly sized conversion nozzle, and reconnect the distributor to the expansion valve. No cutting or soldering is necessary, increasing your efficiency, and saving you time and expense.



Features Include:

- Specific orifice sizes for maximum refrigerant distribution and proper pressure drop
- Dual "O" rings ensure a tight fit with no leakage
- Hard plastic kit contains 168 conversion nozzles
- Nozzles fit both replaceable and non-replaceable nozzle type distributors
- Selection chart helps you choose the best orifice for the job. For further information see Bulletin 20-10-1.



SPECIFICATIONS

ODF Solder Connections – Brass Body

The refrigerant distributors listed on pages 16, 17 and 18 are for use with Sporlan thermostatic expansion valves with ODF solder connections. These include the following valve types: EBF, EBS, EF, EG, EMC, EQ, H, M, O, RC, RI, S, SBF, SQ, and V. These distributors can also be applied to Sporlan OEM type thermostatic expansion valves, or any other thermostatic expansion valve having an ODF outlet connection. If a properly sized refrigerant distributor has a connection size different than the valve outlet, a reducing coupling can be used to connect them.

Material: body - brass
inlet tube - (D260 and D262 only) copper

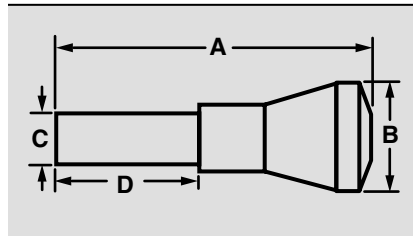
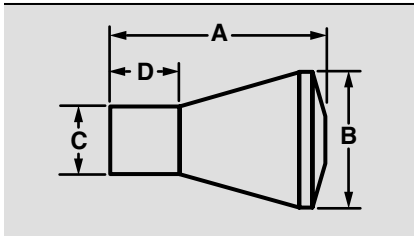

NO. CIRCUITS & TUBING SIZES AVAILABLE	NOZZLE ORIFICE NUMBERS AVAILABLE	NOZZLE & RETAINER RING SIZE	INLET CONNECTION Inches	DISTRIBUTOR	DIMENSIONS Inches			
					A	B	C	D
TYPE D260					Net Weight - Approximately 2 oz.			
2 to 6 - 3/16"	1/9 thru 8	L	1/2 ODM Solder		1.96	0.81	.497 .503	0.82
2 to 4 - 1/4"								
TYPE D262					Net Weight - Approximately 3 oz.			
7 to 9 - 3/16"	1/9 thru 8	L	1/2 ODM Solder		2.44	1.00	.497 .503	0.81
5 to 6 - 1/4"								
2 to 4 - 5/16"								
TYPE 1620					Net Weight - Approximately 2 oz.			
2 to 6 - 3/16"	1/9 thru 8	J	5/8 ODM Solder		1.14	0.81	.623 .625	0.69
2 to 4 - 1/4"								
TYPE 1622					Net Weight - Approximately 3 oz.			
7 to 9 - 3/16"	1/9 thru 8	J	5/8 ODM Solder		1.63	1.00	.623 .625	0.63
5 to 7 - 1/4"								
2 to 4 - 5/16"								
TYPE 1112					Net Weight - Approximately 4 oz.			
5 to 7 - 3/16"	1/6 thru 20	G	7/8 ODM Solder		1.72	0.91	.873 .875	1.00
4 to 6 - 1/4"								
2 to 4 - 5/16"								
2 - 3/8"								

To fulfill manufacturers' special requirements, additional distributors are available on quantity orders. Consult your Sporlan Sales Engineer or write Sporlan Valve Company. READ ORDERING INSTRUCTIONS page 13.

SPECIFICATIONS ODF Solder Connections – Brass Body (continued)

NO. CIRCUITS & TUBING SIZES AVAILABLE	NOZZLE ORIFICE NUMBERS AVAILABLE	NOZZLE & RETAINER RING SIZE	INLET CONNECTION Inches	DISTRIBUTOR	DIMENSIONS Inches			
					A	B	C	D
TYPE 1113					Net Weight - Approximately 5 oz.			
8 to 12 - 3/16"	1/6 thru 20	G	7/8 ODM Solder		1.78	1.16	$\frac{.873}{.875}$	0.88
7 to 8 - 1/4"								
5 to 6 - 5/16"								
3 to 4 - 3/8"								
TYPE 1115					Net Weight - Approximately 9 oz.			
11 to 15 - 3/16"	2 thru 30	E	1-1/8 ODM Solder		2.44	1.50	$\frac{1.123}{1.125}$	1.12
9 to 10 - 1/4"								
7 to 9 - 5/16"								
5 to 6 - 3/8"								
TYPE 1116					Net Weight - Approximately 9 oz.			
16 to 20 - 3/16"	2 thru 30	E	1-1/8 ODM Solder		2.44	1.75	$\frac{1.123}{1.125}$	1.12
11 to 15 - 1/4"								
TYPE 1117					Net Weight - Approximately 1 lb.			
16 to 18 - 3/16"	3 thru 50	C	1-3/8 ODM Solder		2.56	1.75	$\frac{1.373}{1.375}$	1.31
11 to 15 - 1/4"								
9 - 5/16"								
7 - 3/8"								
TYPE 1126					Net Weight - Approximately 1 lb., 6 oz.			
19 to 24 - 3/16"	3 thru 50	C	1-3/8 ODM Solder		2.81	2.38	$\frac{1.373}{1.375}$	1.12
15 to 18 - 1/4"								
10 to 15 - 5/16"								
8 to 12 - 3/8"								
TYPE 1128					Net Weight - Approximately 1 lb., 10 oz.			
25 to 28 - 3/16"	3 thru 50	C	1-3/8 ODM Solder		3.12	3.00	$\frac{1.373}{1.375}$	1.38
19 to 25 - 1/4"								
16 to 21 - 5/16"								
13 to 16 - 3/8"								
TYPE 1125					Net Weight - Approximately 1 lb., 14 oz.			
25 to 28 - 3/16"	10 thru 50	A	1-5/8 ODM Solder		3.12	3.00	$\frac{1.623}{1.625}$	1.30
19 to 24 - 1/4"								
16 to 20 - 5/16"								
13 to 16 - 3/8"								
TYPE 1127					Net Weight - Approximately 2 lb., 4 oz.			
29 to 37 - 3/16"	10 thru 50	A	1-5/8 ODM Solder		3.31	3.50	$\frac{1.623}{1.625}$	1.28
25 to 30 - 1/4"								
21 to 26 - 5/16"								
17 to 20 - 3/8"								
TYPE 1143					Net Weight - Approximately 3 lb.			
29 to 40 - 3/16"	10 thru 50	A	1-5/8 ODM Solder		3.69	4.00	$\frac{1.623}{1.625}$	1.44
31 to 36 - 1/4"								
27 to 30 - 5/16"								
21 to 24 - 3/8"								

To fulfill manufacturers' special requirements, additional distributors are available on quantity orders. Consult your Sporlan Sales Engineer or write Sporlan Valve Company. READ ORDERING INSTRUCTIONS page 13.

SPECIFICATIONS

Flange Connections – Brass Body

The distributors listed below are used with Sporlan Types H, M, and V thermostatic expansion valves.

The Types 1109 and 1124 refrigerant distributors have a male flange ring inlet connection, and bolt directly to the outlet of the Sporlan Type H valve. The Type 1109 refrigerant distributor is supplied with a 2-bolt flange P/N 576-000. This flange is also used for the H valve with 5/8" and 7/8" ODF outlet brass bushings. The Type 1124 refrigerant distributor has an integral 2-bolt flange. It does not require a separate flange.

Gasket P/N 123-002 is used when bolting these distributors to the valve body.

The female flange ring of the Type 1121 distributor mates directly to the Sporlan Types M and V valve outlet.

Gasket P/N 123-000 is used when bolting this distributor to the valve body.

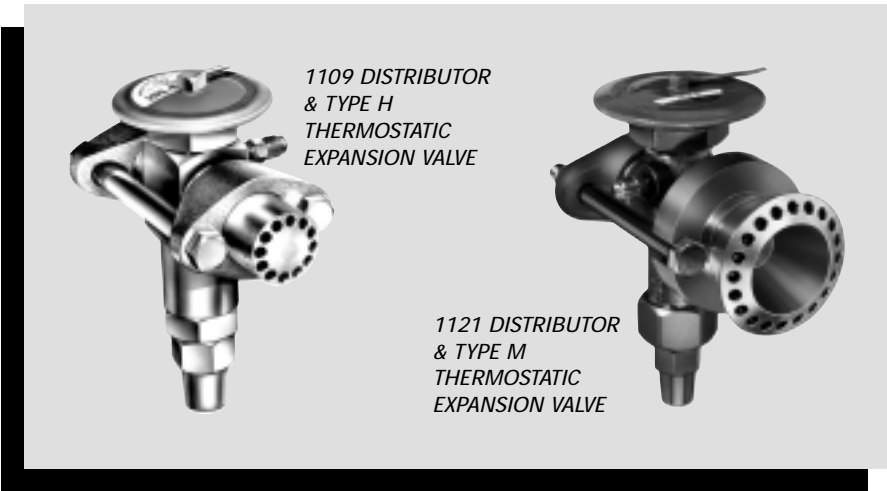

Bolt specifications for each distributor are listed below:

1109 with P/N 576-000 flange: (2) 7/16" 14 THD x 4-1/2" with nuts

1124: (2) 7/16" - 14 THD x 4" with nuts

1121: (2) 1/2" - 13 THD x 5" with nuts

Material: body - brass; 2 bolt flange for Type 1109 distributor - grey cast iron

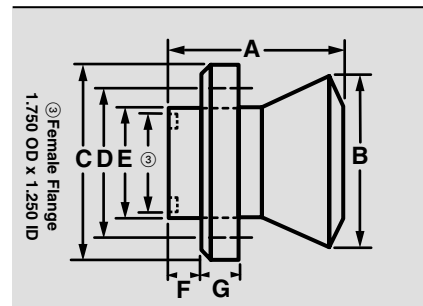
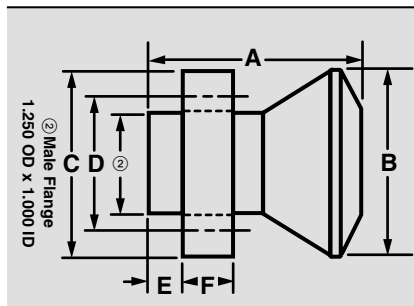
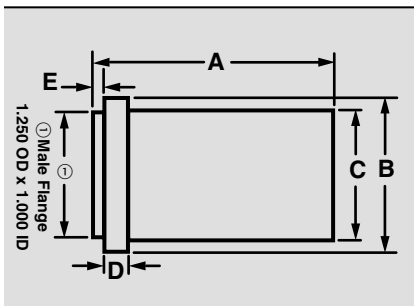

NO. CIRCUITS & TUBING SIZES AVAILABLE	NOZZLE ORIFICE NUMBERS AVAILABLE	NOZZLE & RETAINER RING SIZE	DISTRIBUTOR	DIMENSIONS - Inches							
				A	B	C	D	E	F	G	
TYPE 1109	Net Weight - Approximately 10 oz.										
2 to 10 - 3/16"	1/6 thru 20	G (Used in combination with Sporlan Valve Type H)		2.44	1.37	1.12	0.25	0.12	---	---	
2 to 8 - 1/4"											
2 to 6 - 5/16"											
2 to 4 - 3/8"											
TYPE 1124	Net Weight - Approximately 1 lb., 14 oz.										
13 to 30 - 3/16"	2 thru 30	E (Used in combination with Sporlan Valve Type H)		3.12	2.75	2.75	2.00	0.50	0.75	---	
11 to 23 - 1/4"											
8 to 18 - 5/16"											
7 to 15 - 3/8"											
TYPE 1121	Net Weight - Approximately 3 lb., 12 oz.										
17 to 34 - 3/16"	3 thru 50	C (Used in combination with Sporlan Valve Types M and V)		3.12	3.06	3.35	2.69	2.00	0.56	0.75	
13 to 24 - 1/4"											
10 to 20 - 5/16"											
8 to 16 - 3/8"											

To fulfill manufacturers' special requirements, additional distributors are available on quantity orders. Consult your Sporlan Sales Engineer or write Sporlan Valve Company. READ ORDERING INSTRUCTIONS page 13.

ALUMINUM REFRIGERANT DISTRIBUTORS

For Non-Ammonia Refrigeration Applications

Sporlan aluminum distributors are identical in function, and incorporate the same features as the brass models. General information and sizing recommendations also apply to the aluminum models.

Use Tables A, B, and C on pages 10 thru 13 to select distributor nozzles and tubes.

Aluminum does not solder or braze to copper or brass TEV connections. As a result, Sporlan aluminum distributors bolt to Sporlan flanged connection TEVs. This connection provides a logical transition from a copper liquid line to an aluminum evaporator coil.

The Type 1192 distributor bolts directly to the Sporlan Type H valve. The flange gasket is P/N 123-002.

The Type 1193 distributor bolts directly to Sporlan Types M and V valves. The flange gasket is P/N 123-000.

Aluminum Brazing—Aluminum brazing requires close temperature control because of the narrow range of melting points between the filler metals and the base metal. To maintain close temperature control, oven brazing is often used instead of torch brazing.

Since it is more difficult brazing aluminum tubes to an aluminum distributor, than brazing copper tubes to a brass distributor, Sporlan aluminum distributors have additional space between circuits, reducing the maximum number of circuits.

Brazing copper distributor tubes to an aluminum distributor is not recommended.

Sporlan aluminum distributors are made from 6061-T6 aluminum, and suitable for brazing.

Bolt specifications for each distributor are listed below:

- 1192: (2) 7/16" - 14 THD x 4-1/2" with nuts
- 1193: (2) 1/2" - 13 THD x 5" with nuts

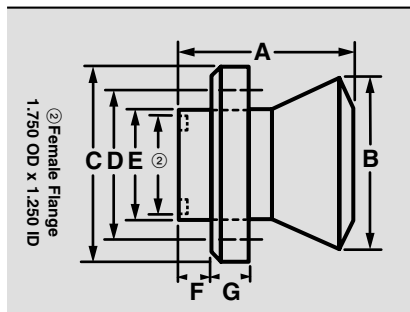
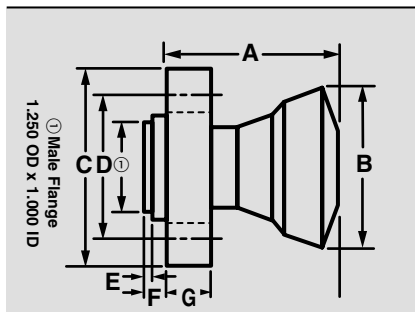

NO. CIRCUITS & TUBING SIZES AVAILABLE	NOZZLE ORIFICE NUMBERS AVAILABLE	NOZZLE & RETAINER RING SIZE	DISTRIBUTOR	DIMENSIONS - Inches							
				A	B	C	D	E	F	G	
TYPE 1192	Net Weight - Approximately 10 oz.				2.69	2.25	2.75	2.00	0.12	0.31	0.62
2 to 11 - 3/16"	1/6 thru 20	G (Used in combination with Sporlan Valve Type H)									
2 to 10 - 1/4"											
2 to 6 - 5/16"											
2 to 6 - 3/8"											
TYPE 1193	Net Weight - Approximately 1 lb., 4 oz.				3.12	3.06	3.50	2.69	2.00	0.56	0.75
12 to 26 - 3/16"	3 thru 50	C (Used in combination with Sporlan Valve Types M and V)									
9 to 21 - 1/4"											
7 to 18 - 5/16"											
7 to 16 - 3/8"											

To fulfill manufacturers' special requirements, additional distributors are available on quantity orders. Consult your Sporlan Sales Engineer or write Sporlan Valve Company. READ ORDERING INSTRUCTIONS page 13.

REFRIGERANT DISTRIBUTORS WITH AUXILIARY SIDE CONNECTIONS

For Non-Ammonia Applications

DISCHARGE BYPASS APPLICATIONS

When bypassing discharge gas through the distributor side connection for capacity control, the main stream of liquid refrigerant issuing from the nozzle may be deflected, affecting refrigerant distribution.

In 1964, Sporlan patented a special extended (Type R) nozzle. The Type R transmits refrigerant flow from the TEV, to the dispersion cone, without influence from the discharge gas flow entering through the side connection.

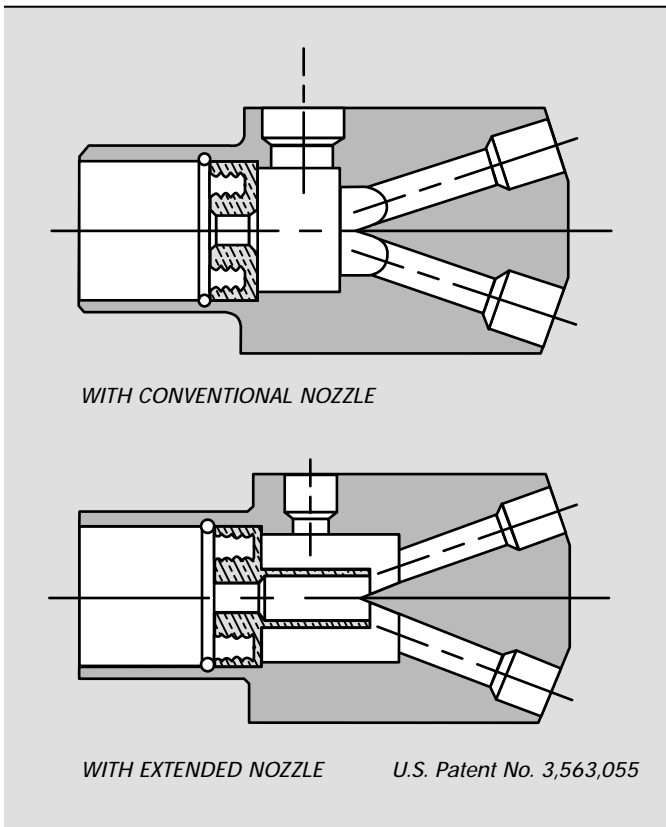

SELECTION

1. **Nozzle Orifice Size**—The nozzle orifice size is selected based on the evaporator coil capacity from Table B, page 11 and 12. See example on page 21.
2. **Distributor Tube and Side Connection Size**—are selected as follows:

Hot gas defrost and hot gas bypass applications—Initially, the tube circuits are selected based on the evaporator coil capacity from Table A, page 10. If the actual load, as a percentage of the tube's published rating, exceeds 100%, then use the next larger tube size. This minimizes pressure drop when the tubes are handling hot gas.

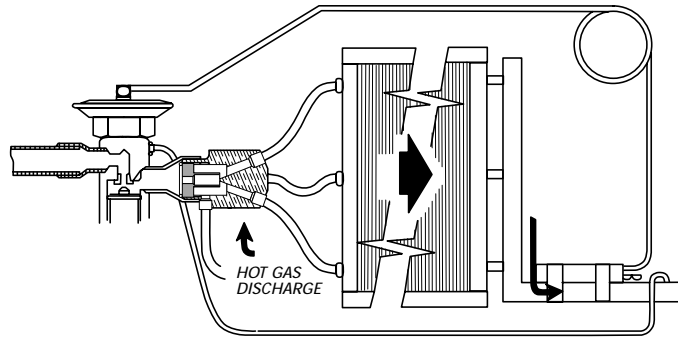

Example:

- R-22
 - 40°F evaporating temperature
 - 100°F liquid refrigerant temperature
 - 8 circuits, 24" tube lengths
 - 12 tons
- Select a tube size assuming hot gas bypass is used for capacity control.
 - Tons per circuit: $12/8 = 1.5$ tons
 - 1/4" OD tube rating in Table A: 1.14 tons
 - Tube rating corrected for tube length:
 $1.14 \times 1.07 = 1.22$ tons
 - Actual load as percentage of published rating:
 $1.5/1.22 = 1.23$ or 123%
 - Select next larger size tube: 5/16" OD since 1/4" OD tube loading is greater than 100%.
 - Type 1655R-8-5/16 distributor may be used.
 - The side outlet connection may be selected to match the hot gas line.

To distinguish side connection distributors with the extended type nozzles from the conventional distributors, the letter "R" is stamped after the designation on the body. For example, the Type **1653R** distributor employs the extended type nozzle. The extended nozzles are also similarly marked: the **GR** nozzle is the extended nozzle used in the Type **1653R** distributor.

The extended nozzle should not be used with the conventional side connection distributors. The standard nozzle, however, can be used with distributors designed for the extended nozzle.

SIDE CONNECTIONS

The maximum size of the side connection is limited by the distributor's internal dimensions. Two side connections located 180° apart can be provided if needed for increased flow. Side connection outlets are drilled to receive standard tubing.

Heat pump or reverse cycle applications—For heat pump and reverse cycle applications the refrigerant distributor needs sufficient capacity for both the refrigeration and reverse cycles. When selecting a 1650 series distributor, the reverse liquid flow capacity is the first consideration. If the distributor is correctly chosen for the reverse cycle, the selection will have ample capacity for the refrigeration cycle. To meet reverse cycle requirements, use Table 4 below to select distributor circuit sizes.

Example:

Select tube size for an outdoor coil assuming the following reverse cycle (cooling mode) conditions:

- R-22
- 40°F evaporating temperature
- 100°F liquid refrigerant temperature
- 5 circuits, 24" tube lengths
- 5 tons
- Tons per circuit: $5/5 = 1.0$ tons
- Looking at Table 4 below, we see pressure drop across 1/4" OD tube to fall between 1.5 and 2 psi. This is an acceptable pressure drop.
- Type 1653 distributor may be used.
- The side outlet connection can be selected from Table 5. In the above example, the smallest acceptable side connection is 1/2" OD.

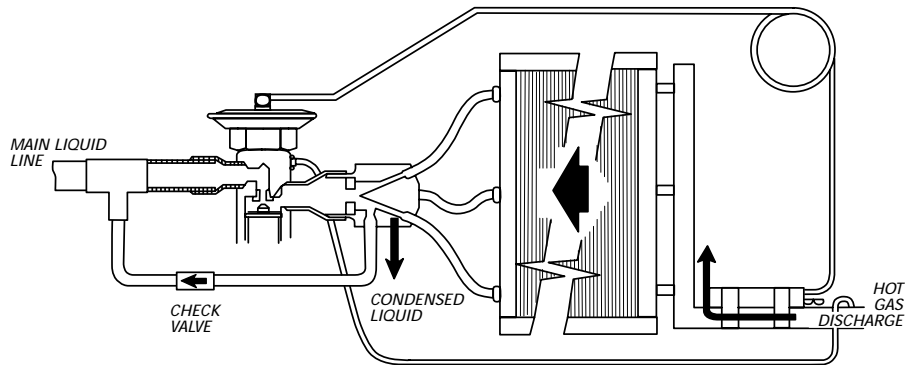

TABLE 4

Reverse Liquid Flow Capacities Per Circuit of Side Outlet Distributors (BTU/HR) at Various Pressure Drops												
TOTAL PRESSURE DROP - psi DISTRIBUTOR and TUBES (9)	DISTRIBUTOR CIRCUIT SIZE											
	3/16" OD TUBE			1/4" OD TUBE			5/16" OD TUBE			3/8" OD TUBE		
	REFRIGERANT											
	12	22	502	12	22	502	12	22	502	12	22	502
1/2	1450	1800	1300	2750	3350	2300	4450	5450	3700	7400	9000	6150
1	2850	3600	2350	5400	6850	4500	8750	11100	7300	14500	18500	12100
1-1/2	4200	5300	3500	7900	10000	6600	12800	16000	10700	21200	26800	17700
2	5450	6900	4550	10300	13000	8600	16700	21000	13900	27600	34800	23000
2-1/2	6600	8800	5500	12500	16500	10400	20500	27000	17100	34000	44000	28300

(9) Maximum length of distributor tubes - 30"

3. Side Connections—are selected as follows:

Hot gas defrost and hot gas bypass applications—For hot gas defrost or hot gas bypass applications the hot gas bypass line size is approximately

equal to the discharge line. Choose the side connection(s) to match the bypass line.

Heat pump or reverse cycle applications—For heat pump applications select the side connection(s) from Table 5 below.

TABLE 5

Maximum Number of Circuits for Various Sizes of Side Connections				
REFRIGERANTS 12, 22, and 502				
SIDE CONNECTIONS ODF SOLDER - Inches (10)	3/16" OD TUBE	1/4" OD TUBE	5/16" OD TUBE	3/8" OD TUBE
3/8	6	3	2	---
1/2	9	5	3	2
5/8	16	8	5	3
7/8	28	15	9	5
1-1/8	---	26	16	10

For two side connections, number of circuits may be doubled.

(10) In some cases it may be necessary to reduce the line size at the distributor to utilize one of the side outlet connections available.

SPECIFICATIONS

SAE Flare Connections – Brass Body with Auxiliary Side Connections

ORDERING INSTRUCTIONS

Proper ordering requires five items:

- **Distributor Type**
See Specification Table below
- **Number of Circuits**
Depends on evaporator design
- **Size Circuits**
See Table-A, Page 10
- **Nozzle Orifice Number**
See Table-B, Page 11 and 12
- **Number and Size of Side Connections**
See Specification Table below



Example:

A coil requires eight 3/16" circuits for a 3 ton load at 40°F refrigerant suction temperature, using Refrigerant 12, plus one 3/8" side connection.

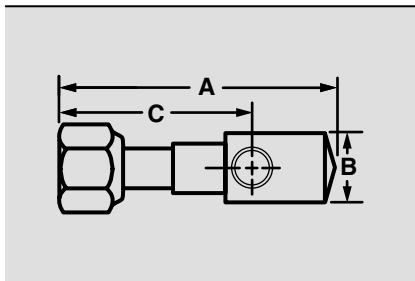

Distributor order would read:

One Distributor, Type 1653, with 8, 3/16" circuits and a 3 Nozzle Orifice Number and one 3/8" side connection, or simplified...

Quantity	Type	Number Circuits	Size Circuits	Nozzle Orifice Number	Number & Size Side Connection
One	1653	8	3/16"	3	One 3/8" side connection

These distributors are supplied with copper tubing and standard short flare nut.

NO. CIRCUITS & TUBING SIZES AVAILABLE	NOZZLE ORIFICE NUMBERS AVAILABLE	SIDE CONNECTIONS		NOZZLE	EXPANSION VALVE OUTLET CONNECTION Inches	DIMENSIONS Inches		
		NUMBER	SIZE Inches			A	B	C
TYPE 1650 & 1650R						Net Weight - Approximately 6 oz.		
2 to 7 - 3/16"	1/9-R thru 5-R or 1/9 thru 5	1 or 2	3/8 or 1/2 ODF Solder	Permanent Not Replaceable	1/2 SAE Flare	3.44	0.88	2.44
2 to 5 - 1/4"								
TYPE 1652 & 1652R						Net Weight - Approximately 7 oz.		
2 to 7 - 3/16"	1/9-R thru 5-R or 1/9 thru 5	1 or 2	3/8 or 1/2 ODF Solder	Permanent Not Replaceable	5/8 SAE Flare	3.75	0.88	2.75
2 to 4 - 1/4"								
TYPE 1654 & 1654R						Net Weight - Approximately 13 oz.		
8 to 12 - 3/16"	1/6-R thru 10-R or 1/6 thru 15	1 or 2	3/8 or 1/2 ODF Solder	Permanent Not Replaceable	5/8 SAE Flare	4.62	1.25	3.31
5 to 9 - 1/4"								
2 to 6 - 5/16"								
2 to 4 - 3/8"								
TYPE 1656 & 1656R						Net Weight - Approximately 1lb., 8 oz.		
13 to 20 - 3/16"	2-R thru 20-R or 2 thru 30	1 or 2	1/2 or 5/8 ODF Solder	Permanent Not Replaceable	5/8 SAE Flare	5.19	1.62	3.38
10 to 12 - 1/4"								
7 to 10 - 5/16"								
5 to 7 - 3/8"								

READ ORDERING INSTRUCTIONS ABOVE.

SPECIFICATIONS

ODF Solder Connections – Brass Body with Auxiliary Side Connections

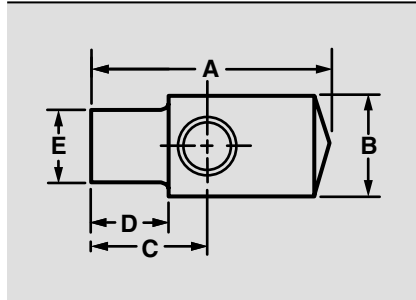

NO. CIRCUITS & TUBING SIZES AVAILABLE	NOZZLE ORIFICE NUMBERS AVAILABLE	SIDE CONNECTIONS		NOZZLE & RETAINER RING SIZE	EXPANSION VALVE OUTLET CONNECTION Inches	USED in COMBINATION with SPORLAN VALVE TYPES	DIMENSIONS Inches				
		NUMBER	SIZE Inches				A	B	C	D	E
TYPE 1651 & 1651R		Net Weight - Approximately 4 oz.									
2 to 7 - 3/16"	1/9-R thru 5-R or 1/9 thru 5	1 or 2	3/8 or 1/2 ODF Solder	JR	5/8 ODF Solder	S, H	1.97	0.88	0.98	0.66	.623 .625
2 to 5 - 1/4"				J							
TYPE 1653 & 1653R		Net Weight - Approximately 10 oz.									
8 to 12 - 3/16"	1/6-R thru 10-R or 1/6 thru 20	1 or 2	3/8 or 1/2 ODF Solder	GR	7/8 ODF Solder	EBS, S, H	2.52	1.25	1.22	0.91	.873 .875
5 to 9 - 1/4"				G							
2 to 6 - 5/16"											
2 to 4 - 3/8"											
TYPE 1655 & 1655R		Net Weight - Approximately 1 lb., 4 oz.									
13 to 20 - 3/16"	2-R thru 20-R or 2 thru 30	1 or 2	1/2 or 5/8 ODF Solder	ER	1-1/8 ODF Solder	EBS, S, O, M, H	3.25	1.62	1.47	1.06	1.123 1.125
10 to 12 - 1/4"				E							
7 to 10 - 5/16"											
5 to 7 - 3/8"											
TYPE 1657 & 1657R		Net Weight - Approximately 3 lb., 2 oz.									
17 to 26 - 3/16"	3-R thru 30-R or 3 thru 50	1 or 2	5/8 or 7/8 ODF Solder	CR	1-3/8 ODF Solder	EBS, O, M	4.25	2.25	1.88	1.31	1.373 1.375
13 to 18 - 1/4"				C							
10 to 14 - 5/16"											
8 to 11 - 3/8"											
TYPE 1659 & 1659R		Net Weight - Approximately 4 lb., 14 oz.									
27 to 32 - 3/16"	3-R thru 30-R or 3 thru 50	1 or 2	7/8 or 1-1/8 ODF Solder	AR	1-5/8 ODF Solder	O, M, V	4.88	2.75	2.31	1.62	1.623 1.626
19 to 24 - 1/4"				A							
15 to 18 - 5/16"											
12 to 14 - 3/8"											

AUXILIARY SIDE CONNECTORS

For non-ammonia applications

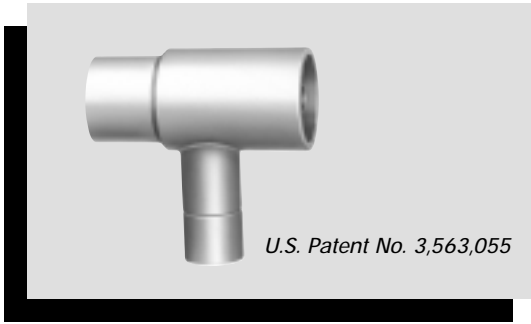

Sporlan auxiliary side connectors (ASCs) permit removable nozzle type Sporlan refrigerant distributors, without side connections, to be used for hot gas bypass, hot gas defrost, or reverse cycle applications, see Figure 5.

The ASC is installed between the TEV and distributor. First, the nozzle and retainer ring are removed from the distributor and reinstalled in the ASC inlet. The ASC outlet is then connected to the distributor inlet. The inlet of the ASC is connected to the TEV outlet.

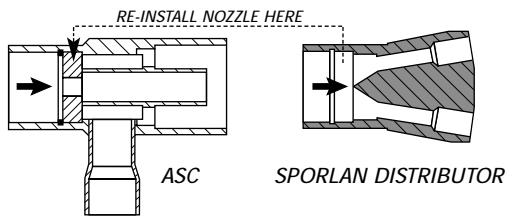

As with side connection type Sporlan distributors, the ASC allows hot gas or liquid refrigerant in the reverse cycle to bypass the nozzle. In addition, the two-phase refrigerant flowing from the TEV passes through the nozzle, and a nozzle tube extension, which terminates at the

SPECIFICATIONS

ASC-4-3, ASC-5-4, ASC-7-4, ASC-9-5, ASC-11-7, and ASC-13-9

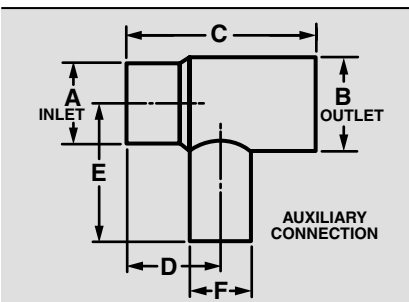

ORDERING INSTRUCTIONS

For proper distributor type, order by complete Sporlan type listed below. E.g., an 1126 distributor requires an ASC-11-7 Auxiliary Side Connector. **Do not use an ASC that is smaller or larger than recommended. Bushing up or down at the outlet defeats the purpose of the internal nozzle tube extension.**

TYPE	CONNECTION SIZES - Inches			USED with DISTRIBUTOR TYPE	NOZZLE SIZE	DIMENSIONS - Inches					
	INLET ODM Solder	OUTLET ODF Solder	AUXILIARY ODF Solder			A	B	C	D	E	F
ASC-4-3	1/2	1/2	3/8	D260, D262	L	1/2 ODM	1/2 ODF	1.75	0.85	1.04	3/8 ODF
ASC-5-4	5/8	5/8	1/2	1620, 1622	J	5/8 ODM	5/8 ODF	1.88	0.95	1.25	1/2 ODF
ASC-7-4	7/8	7/8	1/2	1112, 1113	G	7/8 ODM	7/8 ODF	2.25	1.06	1.38	1/2 ODF
ASC-9-5	1-1/8	1-1/8	5/8	1115, 1116	E	1-1/8 ODM	1-1/8 ODF	2.81	1.47	1.62	5/8 ODF
ASC-11-7	1-3/8	1-3/8	7/8	1117, 1126, 1128	C	1-3/8 ODM	1-3/8 ODF	3.53	1.89	2.19	7/8 ODF
ASC-13-9	1-5/8	1-5/8	1-1/8	1125, 1127, 1143	A	1-5/8 ODM	1-5/8 ODF	3.72	1.83	2.75	1-1/8 ODF

distributor's dispersion cone. This tube eliminates any interference in TEV flow from hot gas flow entering through the side connection. The tube is supported by a perforated web allowing hot gas or liquid refrigerant in the reverse cycle to flow through with minimal pressure drop.

Due to its small size, the ASC-4-3, does not employ any type nozzle tube extension. As a result, it is not suited for hot gas bypass applications. The ASC-4-3, however, is suitable for reverse cycle applications and hot gas defrost.

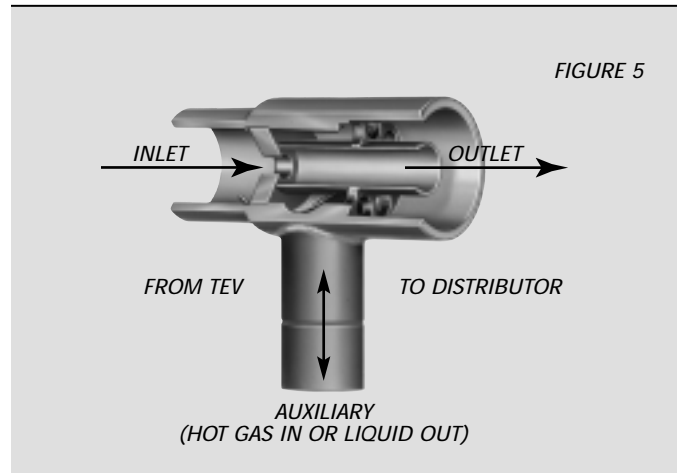

SELECTION

1. Select an ASC which matches the size of the distributor inlet. The table below lists Sporlan distributors and their matching ASC.
2. If the ASC is installed on an existing system, confirm the distributor nozzle orifice size. In addition, verify the distributor tube size is adequate for the application. See examples on page 20 and 21.

SPECIFICATIONS

ASC-H-7 and ASC-M-9 – For Use With Sporlan Type H and M Valves and Flange Type Distributors

ORDERING INSTRUCTIONS

The ASC-H-7 and ASC-M-9 adapt discharge gas bypass on a refrigerant or air conditioning system. They are furnished as a complete kit which includes the connector, two gaskets, two bolts and nuts, Type R nozzle and retaining ring. **Ordering specifications MUST include:**

1. Type of distributor used on system.
2. Orifice number of nozzle required.

If the orifice number of the nozzle is unknown, specify the system capacity, thermostatic expansion valve capacity, evaporating refrigerant temperature, and type of refrigerant in the system. Sporlan will suggest a nozzle suitable for the application.

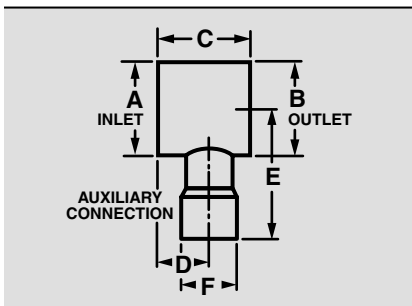

TYPE	CONNECTION SIZES - Inches			USED with DISTRIBUTOR TYPE	NOZZLE SIZE*	DIMENSIONS - Inches					
	INLET	OUTLET	AUXILIARY ODF Solder			A	B	C	D	E	F
ASC-H-7	Male Flange	Female Flange	7/8	1109, 1110, 1124, 1192	ER	Male Flange Ring 1.25 OD x 1.00 ID	Female Flange Ring 1.25 OD x 1.00 ID	1.50	0.87	2.10	7/8
ASC-M-9	Female Flange	Male Flange	1-1/8	1119, 1121, 1193	CR	Female Flange Ring 1.75 OD x 1.25 ID	Male Flange Ring 1.75 OD x 1.25 ID	2.00	1.12	2.81	1-1/8

*Maximum nozzle orifice number for ER is 20, for CR is 30.

IMPORTANT: If the distributor has a nozzle installed it must be removed and discarded. Only the Type R nozzle, furnished with the ASC, should be used.

R-717 (Ammonia) REFRIGERANT DISTRIBUTORS

Sporlan refrigerant distributors for R-717 function like our conventional brass models.

Steel models—The distributor body is Type 8620 vacuum degassed steel. The nozzle is Type 303 stainless steel, and the dispersion cone in the distributor is made of Stellite.

Distributor tube connections are available for 3/16", 1/4", and 5/16" OD steel tubing. The ODF connections are trepanned to facilitate welding the joint. A 1/8" NPT connection is also available with Types 1130, 1133, and 1138 distributors.

Aluminum models—These distributors are designed for R-717 aluminum coils, and they are 6061-T6 aluminum. As with the steel distributors, the dispersion cone is Stellite, and the nozzle is stainless steel.

Distributor tube connections are available for 3/16", 1/4", and 5/16" OD aluminum tubing. Aluminum brazing techniques require more space between circuits than copper

to brass brazing. As a result, the maximum number of circuits is less than for comparable brass models.

APPLICATION to R-717 TEVs

All Type D and Type A TEVs up to and including 50 tons, employ a discharge tube. The discharge tube reduces refrigerant velocity across the valve port, preventing premature pin and seat erosion. When a distributor is used with these valves, the distributor nozzle performs the discharge tube's function. The discharge tube **must** then be removed from the valve to avoid excessive pressure drop.

Distributor performance is best obtained if the distributor is bolted directly to the TEV outlet. When it is not possible to bolt the TEV to the distributor, or if a shut off valve is installed between them, use a short, straight piece of pipe to connect the two. The pipe should not exceed two feet. It should be sized to maintain high refrigerant velocities. Elbows between the TEV and distributor are not recommended since they hinder proper distribution.

SPECIFICATIONS

Refrigerant 717 – Ammonia with Auxiliary Side Connection

The Type 1133 distributor bolts directly to the Type D valve. This distributor features a side connection for hot gas bypass, hot gas defrost, or reverse cycle defrost applications.

Two 7/16" - 13 THD 2" long bolts connect these distributors to the Type D valve.

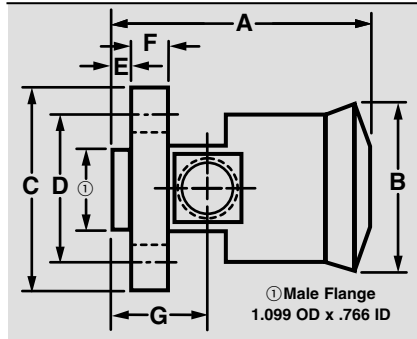
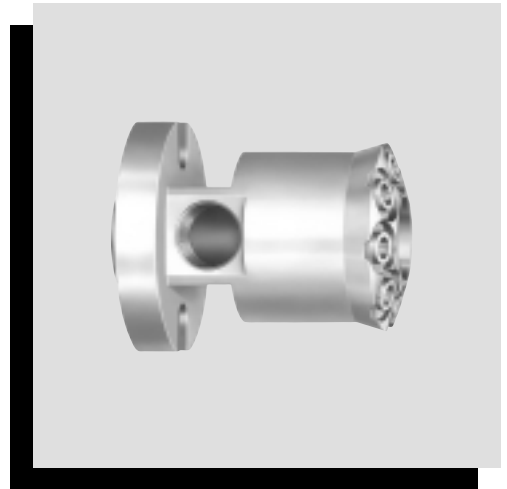

NO. CIRCUITS & TUBING SIZES AVAILABLE	NOZZLE ORIFICE NUMBERS AVAILABLE	SIDE CONNECTIONS		NOZZLE & RETAINER RING SIZE	DIMENSIONS Inches						
		NUMBER	SIZE Inches		A	B	C	D	E	F	G
TYPE 1133 Steel	Net Weight - Approximately 2 lb., 10 oz.			G Used in combination with Sporlan Valve Type DAE and XD Strainer or DAE, XD Strainer and MA5A3 Solenoid Valve, or XD Strainer with Spacer Part No.1177.	3.44	2.25	2.75	2.00	0.25	0.50	1.25
2 to 10 - 3/16" - ODF Welded	1A thru 30A	1	3/8 or 1/2 FPT								
2 to 8 - 1/4" - ODF Welded											
2 to 6 - 5/16" - ODF Welded											
2 to 6 - 1/8" - NPT											

TYPE	DIMENSIONS - Inches				
	A	B	C	D	E
1132	0.19	3.50	1.19	3.44	1.56
1180				4.38	
1130	1.38	3.50	1.19	3.44	1.56
1182				4.38	
1133	1.75	4.00	4.75	4.12	2.75
1182				3.44	
1185				3.44	
FLANGE					
1176-000	0.62	3.00	2.00	---	---
576-000	0.94			---	---

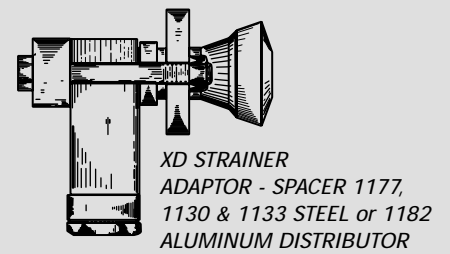
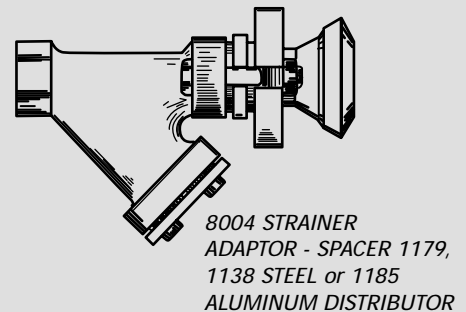
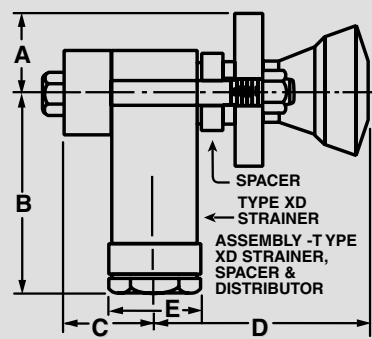

STEEL FLANGE NO. 576-000 for TYPE 1132 and 1180 DISTRIBUTORS

ALUMINUM FLANGE NO. 1176-000 for TYPE 1180 DISTRIBUTOR

